

LN-9 GMA and LN-9F GMA Wire Feeder

For use with machines having Code Numbers: 9100 and Above

Safety Depends on You

Lincoln arc welding equipment is designed and built with safety in mind. However, your overall safety can be increased by proper installation. . . and thoughtful operation on your part. **DO NOT INSTALL, OPERATE OR REPAIR THIS EQUIPMENT WITHOUT READING THIS MANUAL AND THE SAFETY PRECAUTIONS CONTAINED THROUGHOUT.** And, most importantly, think before you act and be careful.

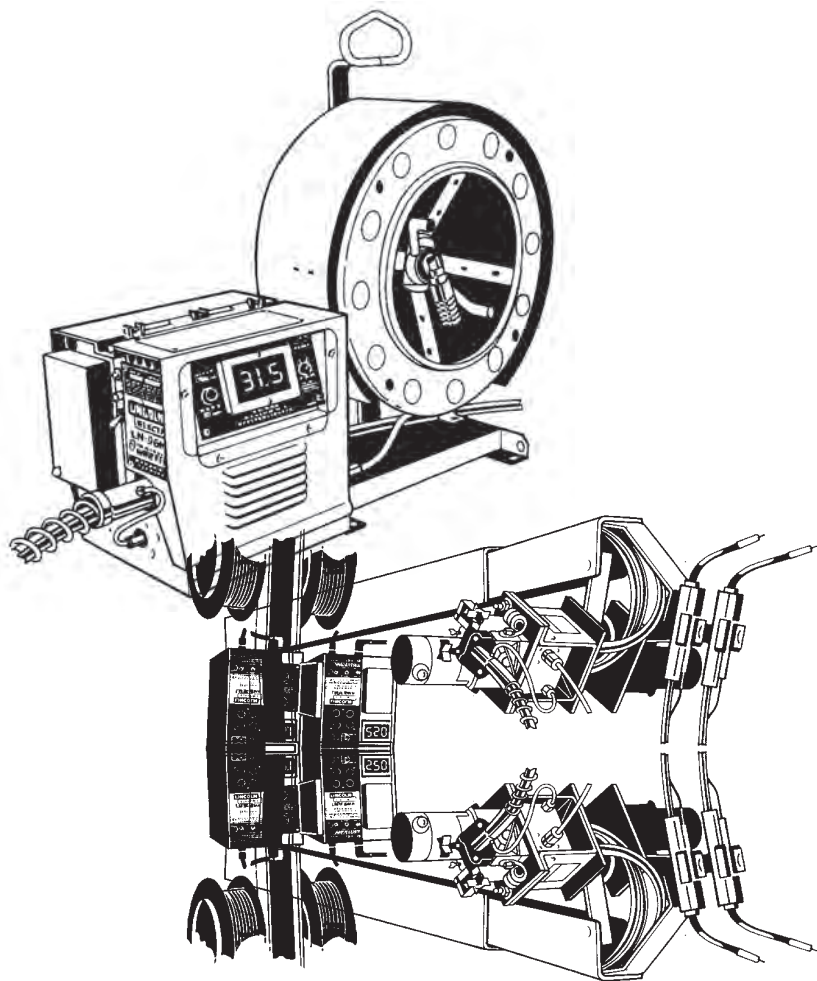

OPERATOR'S MANUAL



LINCOLN[®]
ELECTRIC

- World's Leader in Welding and Cutting Products •
- Sales and Service through Subsidiaries and Distributors Worldwide •

Cleveland, Ohio 44117-1199 U.S.A. TEL: 216.481.8100 FAX: 216.486.1751 WEB SITE: www.lincolnelectric.com

⚠ WARNING

⚠ CALIFORNIA PROPOSITION 65 WARNINGS ⚠

Diesel engine exhaust and some of its constituents are known to the State of California to cause cancer, birth defects, and other reproductive harm.

The Above For Diesel Engines

The engine exhaust from this product contains chemicals known to the State of California to cause cancer, birth defects, or other reproductive harm.

The Above For Gasoline Engines

ARC WELDING CAN BE HAZARDOUS. PROTECT YOURSELF AND OTHERS FROM POSSIBLE SERIOUS INJURY OR DEATH. KEEP CHILDREN AWAY. PACEMAKER WEARERS SHOULD CONSULT WITH THEIR DOCTOR BEFORE OPERATING.

Read and understand the following safety highlights. For additional safety information, it is strongly recommended that you purchase a copy of "Safety in Welding & Cutting - ANSI Standard Z49.1" from the American Welding Society, P.O. Box 351040, Miami, Florida 33135 or CSA Standard W117.2-1974. A Free copy of "Arc Welding Safety" booklet E205 is available from the Lincoln Electric Company, 22801 St. Clair Avenue, Cleveland, Ohio 44117-1199.

BE SURE THAT ALL INSTALLATION, OPERATION, MAINTENANCE AND REPAIR PROCEDURES ARE PERFORMED ONLY BY QUALIFIED INDIVIDUALS.



FOR ENGINE powered equipment.

1.a. Turn the engine off before troubleshooting and maintenance work unless the maintenance work requires it to be running.



1.b. Operate engines in open, well-ventilated areas or vent the engine exhaust fumes outdoors.



1.c. Do not add the fuel near an open flame welding arc or when the engine is running. Stop the engine and allow it to cool before refueling to prevent spilled fuel from vaporizing on contact with hot engine parts and igniting. Do not spill fuel when filling tank. If fuel is spilled, wipe it up and do not start engine until fumes have been eliminated.

1.d. Keep all equipment safety guards, covers and devices in position and in good repair. Keep hands, hair, clothing and tools away from V-belts, gears, fans and all other moving parts when starting, operating or repairing equipment.

1.e. In some cases it may be necessary to remove safety guards to perform required maintenance. Remove guards only when necessary and replace them when the maintenance requiring their removal is complete. Always use the greatest care when working near moving parts.



1.f. Do not put your hands near the engine fan. Do not attempt to override the governor or idler by pushing on the throttle control rods while the engine is running.

1.g. To prevent accidentally starting gasoline engines while turning the engine or welding generator during maintenance work, disconnect the spark plug wires, distributor cap or magneto wire as appropriate.



1.h. To avoid scalding, do not remove the radiator pressure cap when the engine is hot.



ELECTRIC AND MAGNETIC FIELDS may be dangerous

2.a. Electric current flowing through any conductor causes localized Electric and Magnetic Fields (EMF). Welding current creates EMF fields around welding cables and welding machines

2.b. EMF fields may interfere with some pacemakers, and welders having a pacemaker should consult their physician before welding.

2.c. Exposure to EMF fields in welding may have other health effects which are now not known.

2.d. All welders should use the following procedures in order to minimize exposure to EMF fields from the welding circuit:

2.d.1. Route the electrode and work cables together - Secure them with tape when possible.

2.d.2. Never coil the electrode lead around your body.

2.d.3. Do not place your body between the electrode and work cables. If the electrode cable is on your right side, the work cable should also be on your right side.

2.d.4. Connect the work cable to the workpiece as close as possible to the area being welded.

2.d.5. Do not work next to welding power source.



ELECTRIC SHOCK can kill.

3.a. The electrode and work (or ground) circuits are electrically “hot” when the welder is on. Do not touch these “hot” parts with your bare skin or wet clothing. Wear dry, hole-free gloves to insulate hands.

3.b. Insulate yourself from work and ground using dry insulation. Make certain the insulation is large enough to cover your full area of physical contact with work and ground.

In addition to the normal safety precautions, if welding must be performed under electrically hazardous conditions (in damp locations or while wearing wet clothing; on metal structures such as floors, gratings or scaffolds; when in cramped positions such as sitting, kneeling or lying, if there is a high risk of unavoidable or accidental contact with the workpiece or ground) use the following equipment:

- Semiautomatic DC Constant Voltage (Wire) Welder.
- DC Manual (Stick) Welder.
- AC Welder with Reduced Voltage Control.

3.c. In semiautomatic or automatic wire welding, the electrode, electrode reel, welding head, nozzle or semiautomatic welding gun are also electrically “hot”.

3.d. Always be sure the work cable makes a good electrical connection with the metal being welded. The connection should be as close as possible to the area being welded.

3.e. Ground the work or metal to be welded to a good electrical (earth) ground.

3.f. Maintain the electrode holder, work clamp, welding cable and welding machine in good, safe operating condition. Replace damaged insulation.

3.g. Never dip the electrode in water for cooling.

3.h. Never simultaneously touch electrically “hot” parts of electrode holders connected to two welders because voltage between the two can be the total of the open circuit voltage of both welders.

3.i. When working above floor level, use a safety belt to protect yourself from a fall should you get a shock.

3.j. Also see Items 6.c. and 8.



ARC RAYS can burn.

4.a. Use a shield with the proper filter and cover plates to protect your eyes from sparks and the rays of the arc when welding or observing open arc welding. Headshield and filter lens should conform to ANSI Z87.1 standards.

4.b. Use suitable clothing made from durable flame-resistant material to protect your skin and that of your helpers from the arc rays.

4.c. Protect other nearby personnel with suitable, non-flammable screening and/or warn them not to watch the arc nor expose themselves to the arc rays or to hot spatter or metal.



FUMES AND GASES can be dangerous.

5.a. Welding may produce fumes and gases hazardous to health. Avoid breathing these fumes and gases. When welding, keep your head out of the fume. Use enough ventilation and/or exhaust at the arc to keep fumes and gases away from the breathing zone. **When welding with electrodes which require special ventilation such as stainless or hard facing (see instructions on container or MSDS) or on lead or cadmium plated steel and other metals or coatings which produce highly toxic fumes, keep exposure as low as possible and within applicable OSHA PEL and ACGIH TLV limits using local exhaust or mechanical ventilation. In confined spaces or in some circumstances, outdoors, a respirator may be required. Additional precautions are also required when welding on galvanized steel.**

5.b. The operation of welding fume control equipment is affected by various factors including proper use and positioning of the equipment, maintenance of the equipment and the specific welding procedure and application involved. Worker exposure level should be checked upon installation and periodically thereafter to be certain it is within applicable OSHA PEL and ACGIH TLV limits.

5.c. Do not weld in locations near chlorinated hydrocarbon vapors coming from degreasing, cleaning or spraying operations. The heat and rays of the arc can react with solvent vapors to form phosgene, a highly toxic gas, and other irritating products.

5.d. Shielding gases used for arc welding can displace air and cause injury or death. Always use enough ventilation, especially in confined areas, to insure breathing air is safe.

5.e. Read and understand the manufacturer’s instructions for this equipment and the consumables to be used, including the material safety data sheet (MSDS) and follow your employer’s safety practices. MSDS forms are available from your welding distributor or from the manufacturer.

5.f. Also see item 1.b.

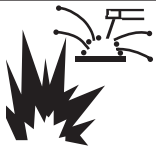

WELDING and CUTTING SPARKS can cause fire or explosion.

6.a. Remove fire hazards from the welding area. If this is not possible, cover them to prevent the welding sparks from starting a fire.

Remember that welding sparks and hot materials from welding can easily go through small cracks and openings to adjacent areas. Avoid welding near hydraulic lines. Have a fire extinguisher readily available.

- 6.b. Where compressed gases are to be used at the job site, special precautions should be used to prevent hazardous situations. Refer to "Safety in Welding and Cutting" (ANSI Standard Z49.1) and the operating information for the equipment being used.
- 6.c. When not welding, make certain no part of the electrode circuit is touching the work or ground. Accidental contact can cause overheating and create a fire hazard.
- 6.d. Do not heat, cut or weld tanks, drums or containers until the proper steps have been taken to insure that such procedures will not cause flammable or toxic vapors from substances inside. They can cause an explosion even though they have been "cleaned". For information, purchase "Recommended Safe Practices for the Preparation for Welding and Cutting of Containers and Piping That Have Held Hazardous Substances," AWS F4.1 from the American Welding Society (see address above).
- 6.e. Vent hollow castings or containers before heating, cutting or welding. They may explode.
- 6.f. Sparks and spatter are thrown from the welding arc. Wear oil free protective garments such as leather gloves, heavy shirt, cuffless trousers, high shoes and a cap over your hair. Wear ear plugs when welding out of position or in confined places. Always wear safety glasses with side shields when in a welding area.
- 6.g. Connect the work cable to the work as close to the welding area as practical. Work cables connected to the building framework or other locations away from the welding area increase the possibility of the welding current passing through lifting chains, crane cables or other alternate circuits. This can create fire hazards or overheat lifting chains or cables until they fail.
- 6.h. Also see item 1.c.
- 6.i. Read and follow NFPA 51B "Standard for Fire Prevention During Welding, Cutting and Other Hot Work," available from NFPA, 1 Batterymarch Park, PO box 9101, Quincy, Ma 022690-9101.
- 6.j. Do not use a welding power source for pipe thawing.



CYLINDER may explode if damaged.

- 7.a. Use only compressed gas cylinders containing the correct shielding gas for the process used and properly operating regulators designed for the gas and pressure used. All hoses, fittings, etc. should be suitable for the application and maintained in good condition.
- 7.b. Always keep cylinders in an upright position securely chained to an undercarriage or fixed support.
- 7.c. Cylinders should be located:
 - Away from areas where they may be struck or subjected to physical damage.
 - A safe distance from arc welding or cutting operations and any other source of heat, sparks, or flame.
- 7.d. Never allow the electrode, electrode holder or any other electrically "hot" parts to touch a cylinder.
- 7.e. Keep your head and face away from the cylinder valve outlet when opening the cylinder valve.
- 7.f. Valve protection caps should always be in place and hand tight except when the cylinder is in use or connected for use.
- 7.g. Read and follow the instructions on compressed gas cylinders, associated equipment, and CGA publication P-1, "Precautions for Safe Handling of Compressed Gases in Cylinders," available from the Compressed Gas Association 1235 Jefferson Davis Highway, Arlington, VA 22202.



FOR ELECTRICALLY powered equipment.

- 8.a. Turn off input power using the disconnect switch at the fuse box before working on the equipment.
- 8.b. Install equipment in accordance with the U.S. National Electrical Code, all local codes and the manufacturer's recommendations.
- 8.c. Ground the equipment in accordance with the U.S. National Electrical Code and the manufacturer's recommendations.

Refer to <http://www.lincolnelectric.com/safety> for additional safety information.

PRÉCAUTIONS DE SÛRETÉ

Pour votre propre protection lire et observer toutes les instructions et les précautions de sûreté spécifiques qui paraissent dans ce manuel aussi bien que les précautions de sûreté générales suivantes:

Sûreté Pour Soudage A L'Arc

1. Protégez-vous contre la secousse électrique:
 - a. Les circuits à l'électrode et à la pièce sont sous tension quand la machine à souder est en marche. Eviter toujours tout contact entre les parties sous tension et la peau nue ou les vêtements mouillés. Porter des gants secs et sans trous pour isoler les mains.
 - b. Faire très attention de bien s'isoler de la masse quand on soude dans des endroits humides, ou sur un plancher métallique ou des grilles métalliques, principalement dans les positions assis ou couché pour lesquelles une grande partie du corps peut être en contact avec la masse.
 - c. Maintenir le porte-électrode, la pince de masse, le câble de soudage et la machine à souder en bon et sûr état de fonctionnement.
 - d. Ne jamais plonger le porte-électrode dans l'eau pour le refroidir.
 - e. Ne jamais toucher simultanément les parties sous tension des porte-électrodes connectés à deux machines à souder parce que la tension entre les deux pinces peut être le total de la tension à vide des deux machines.
2. Dans le cas de travail au dessus du niveau du sol, se protéger contre les chutes dans le cas où on recoit un choc. Ne jamais enroule le câble-électrode autour de n'importe quelle partie du corps.
3. Un coup d'arc peut être plus sévère qu'un coup de soliel, donc:
 - a. Utiliser un bon masque avec un verre filtrant approprié ainsi qu'un verre blanc afin de se protéger les yeux du rayonnement de l'arc et des projections quand on soude ou quand on regarde l'arc.
 - b. Porter des vêtements convenables afin de protéger la peau de soudeur et des aides contre le rayonnement de l'arc.
 - c. Protéger l'autre personnel travaillant à proximité au soudage à l'aide d'écrans appropriés et non-inflammables.
4. Des gouttes de laitier en fusion sont émises de l'arc de soudage. Se protéger avec es vêtements de protection libres de l'huile, tels que les gants en cuir, chemise épaisse, pantalons sans revers, et chaussures montantes.
5. Toujours porter des lunettes de sécurité dans la zone de soudage. Utiliser des lunettes avec écrans latéraux dans les zones où l'on pique le laitier.
6. Eloigner les matériaux inflammables ou les recouvrir afin de prévenir tout risque d'incendie dû étincelles.

7. Quand on ne soude pas, poser la pince à une endroit isolé de la masse. Un court-circuit accidentel peut provoquer un échauffement et un risque d'incendie.
8. S'assurer que la masse est connectée le plus près possible de la zone de travail qu'il est pratique de la faire. Si on place la masse sur la charpente de la construction ou d'autres endroits éloignés de la zone de travail, on augmente le risque de voir passer le courant de soudage par les chaines de levage, câbles de grue, ou autres circuits. Cela peut provoquer des risques d'incendie ou d'échauffement des chaines et des câbles jusqu'à ce qu'ils se rompent.
9. Assurer une ventilation suffisante dans la zone de soudage. Ceci est particulièrement important pour le soudage de tôles galvanisées plombées, ou cadmiées ou tout autre métal qui produit des fumées toxiques.
10. Ne pas souder en présence de vapeurs de chlore provenant d'opérations de dégraissage, nettoyage ou pistolage. La chaleur ou les rayons de l'arc peuvent réagir avec les vapeurs du solvant pour produire du phosgène (gas fortement roxique) ou autres produits irritants.

PRÉCAUTIONS DE SÛRETÉ POUR LES MACHINES À SOUDER À TRANSFORMATEUR ET À REDRESSEUR

1. Relier à la terre le chassis du poste conformément au code de l'électricité et aux recommandations du fabricant. Le dispositif de montage ou la piece à souder doit être branché à une bonne mise à la terre.
2. Autant que possible, l'installation et l'entretien du poste seront effectués par un électricien qualifié.
3. Avant de faire des travaux à l'intérieur de poste, la débrancher à l'interrupteur à la boîte de fusibles.
4. Garder tous les couvercles et dispositifs de sûreté à leur place.

Thank You

for selecting a **QUALITY** product by Lincoln Electric. We want you to take pride in operating this Lincoln Electric Company product ••• as much pride as we have in bringing this product to you!

CUSTOMER ASSISTANCE POLICY

The business of The Lincoln Electric Company is manufacturing and selling high quality welding equipment, consumables, and cutting equipment. Our challenge is to meet the needs of our customers and to exceed their expectations. On occasion, purchasers may ask Lincoln Electric for advice or information about their use of our products. We respond to our customers based on the best information in our possession at that time. Lincoln Electric is not in a position to warrant or guarantee such advice, and assumes no liability, with respect to such information or advice. We expressly disclaim any warranty of any kind, including any warranty of fitness for any customer's particular purpose, with respect to such information or advice. As a matter of practical consideration, we also cannot assume any responsibility for updating or correcting any such information or advice once it has been given, nor does the provision of information or advice create, expand or alter any warranty with respect to the sale of our products.

Lincoln Electric is a responsive manufacturer, but the selection and use of specific products sold by Lincoln Electric is solely within the control of, and remains the sole responsibility of the customer. Many variables beyond the control of Lincoln Electric affect the results obtained in applying these types of fabrication methods and service requirements.

Subject to Change – This information is accurate to the best of our knowledge at the time of printing. Please refer to www.lincolnelectric.com for any updated information.

Please Examine Carton and Equipment For Damage Immediately

When this equipment is shipped, title passes to the purchaser upon receipt by the carrier. Consequently, Claims for material damaged in shipment must be made by the purchaser against the transportation company at the time the shipment is received.

Please record your equipment identification information below for future reference. This information can be found on your machine nameplate.

Product _____

Model Number _____

Code Number or Date Code _____

Serial Number _____

Date Purchased _____

Where Purchased _____

Whenever you request replacement parts or information on this equipment, always supply the information you have recorded above. The code number is especially important when identifying the correct replacement parts.

On-Line Product Registration

- Register your machine with Lincoln Electric either via fax or over the Internet.
 - For faxing: Complete the form on the back of the warranty statement included in the literature packet accompanying this machine and fax the form per the instructions printed on it.
 - For On-Line Registration: Go to our **WEB SITE at www.lincolnelectric.com**. Choose "Quick Links" and then "Product Registration". Please complete the form and submit your registration.

Read this Operators Manual completely before attempting to use this equipment. Save this manual and keep it handy for quick reference. Pay particular attention to the safety instructions we have provided for your protection. The level of seriousness to be applied to each is explained below:

WARNING

This statement appears where the information **must** be followed **exactly** to avoid **serious personal injury** or **loss of life**.

CAUTION

This statement appears where the information **must** be followed to avoid **minor personal injury** or **damage to this equipment**.

	Page
Safety	i-iv
<hr/>	
Installation	Section A
Technical Specifications	A-1
Installing the LN-9GMA 2-Roll and 4-Roll Models	A-2
Attaching the Wire Reel stand	A-2
Mounting the Unit	A-2
Installing the LN-9F GMA 2-Roll and 4-Roll Models	A-2
Mounting the Wire Feed Unit.....	A-2
Mounting the Control Box	A-2
Connecting the Wire Feed Unit to the Control Box	A-2
Routing the Electrode	A-3
Electrical Connections - LN-9 GMA and LN-9F GMA.....	A-3
Power Input Cable Assembly.....	A-3
Connecting the Power Input Cable Assembly to the LN-9 GMA Wire Feed Unit.....	A-3
Connecting the Power Input Cable Assembly to the LN-9F GMA Wire Feed Unit	A-4
Connecting the Power Input Cable Assembly to Power Sources	A-4
Machine Grounding.....	A-12
Work Cable Connection	A-12
Direct Work Cable Connection	A-12
Connecting the Gun Cable to the Wire Feeder	A-13
For GMA Gun Cables	A-13
Hooking Up GMA Shielding Gas.....	A-14
<hr/>	
Operation	Section B
Operating Instructions	B-1
Safety Precautions	B-1
General Description	B-2
Recommended Processes and Equipment.....	B-2
K424 LN-9 GMA 2-Roll and K568-1 LN-9 GMA 4-Roll.....	B-2
K436 LN-9F GMA 2-Roll and K583-1 LN-9F GMA 4-Roll	B-2
DC Constant Voltage Power Sources	B-3
Controls and Settings.....	B-4
Circuit Protection and Automatic Shutdown	B-7
Avoiding Grounding Lead Protector (GLP) Shutdown.....	B-7

TABLE OF CONTENTS *(cont'd)*

Drive Roll Installation	B-9
Changing Drive Rolls for 2-Roll Wire Feeders	B-9
Changing Drive Rolls for 4-Roll Wire Feeders.....	B-11
Wire Loading	B-13
Loading a 22 to 30 lb. Reddi-Reel Package.....	B-13
Loading a 10 to 30 lb. Spool	B-14
Loading 50 and 60 lb. Coils.....	B-15
Loading and Feeding 13-14 lbs. Innershield Coils.....	B-16
Idle Roll Pressure Setting	B-17
2-Roll Wire Feeders.....	B-17
4-Roll Wire Feeders.....	B-17
Making a Test Weld and Adjusting Response and Starting	B-18
Adjust the Power Source	B-18
Adjust the LN9 GMA Controls	B-18
Voltage Control Response.....	B-19
Starting Characteristics.....	B-19
Making a Weld.....	B-20
Procedure at End of Coil	B-20
Security of Weld Procedure Settings.....	B-20

Accessories	Section C
Auxiliary Equipment Contacts.....	C-1
Optional Equipment and Accessories.....	C-1
Power Input Cable Assemblies (K196, K595, K596).....	C-1
Wire Reel Stands and Mountings.....	C-1
Gun and Cable Assemblies	C-3
Wire Feeder Accessories	C-3

Maintenance	Section D
Routine Maintenance	D-1
Drive Rolls and Guide Tubes	D-1
Wire Reel Mounting – 50 and 60 lb. Coils	D-1
Wire Reel Mounting REDI-Reels and Spools.....	D-1
Periodic Maintenance	D-1
Control Box.....	D-1
Wire Drive Motor and Gear Box.....	D-1

TABLE OF CONTENTS *(cont'd)*

Gun and Cable Maintenance	D-2
Proper Speed Sensor Motor Mounting.....	D-2
Gun Cable Connector Requirements	D-3

Troubleshooting	Section E
How to Use Troubleshooting Guide	E-1
Troubleshooting Guide	E-2

Diagrams	Section F
LN-9 GMA Wiring Diagram.....	F-1
LN-9F GMA Wiring Diagram	F-2
LN-9 GMA Dimension Print	F-3
LN-9F GMA Dimension Prints	F-4

Parts	P127, P125, P107 & P289 Series
--------------------	---

TECHNICAL SPECIFICATIONS

INPUT POWER

Supplied by power source: 115 VAC, 50/60 Hz., 350 VA

WIRE FEED SPEED

80 to 980 inches per minute (2.03 to 24.9 meters per minute)

VOLTAGE CONTROL RANGE

12.0 TO 60.0 VDC

TEMPERATURE RANGE

OPERATION:	- 20° C to +40° C (- 4° F to +104° F) - 40° C to +40° C (- 40° F to +104° F)	Recommended Maximum Rated
STORAGE:	- 40° C to +85° C (- 40° F to +185° F)	

WIRE DIAMETERS

0.023 through 1/16
0.045 through 5/64

Solid Electrode
Cored Electrode

PHYSICAL DIMENSIONS

	LENGTH	WIDTH	HEIGHT	TOTAL WEIGHT LESS ELECTRODE
LN-9 GMA (2 ROLL)	12.15 in. (308.4 mm)	11.56 in. (293.4 mm)	12.19 in. (309.4 mm)	29.3 lbs (13.3 kg)
LN-9 GMA (4 ROLL)	12.15 in. (308.4 mm)	11.56 in. (293.4 mm)	12.19 in. (309.4 mm)	27.5 lbs (12.4 kg)
LN-9F GMA Control Box	10.4 in. (264 mm)	6.17 in. (156.6 mm)	11.26 in. (293.4 mm)	16.3 lbs (7.4 kg)
LN-9F GMA Wire Drive (2 ROLL)	8.06 in. (204.6 mm)	7.5 in. (190.4 mm)	12.78 in. (324.4 mm)	15.6 lbs (7.1 kg)
LN-9F GMA Wire Drive (4 ROLL)	8.06 in. (204.6 mm)	7.5 in. (190.4 mm)	12.78 in. (324.4 mm)	20.5 lbs (9.2 kg)

DUTY CYCLE: The amount of welding performed in a 10 minute period, expressed as a percentage.

LN-9 GMA and LN-9F GMA Wire Feeder



INSTALLATION

INSTALLING THE LN-9 GMA 2-ROLL AND 4-ROLL MODELS

ATTACHING THE WIRE REEL STAND

Both the 2-Roll and 4-Roll LN-9 GMA are shipped without the wire reel stand attached. The screws and washers for mounting the wire reel stand are included with the LN-9 GMA (fastened in their respective mounting holes). To attach the stand:

1. Remove the three 3/8" hex screws from the back of the wire feed unit.
2. Place the wire reel stand mounting bracket in position against the back of the wire feed unit.
3. Replace and tighten the screws. The long screw and plain washer go into the top hole. For 4-Roll feeders, one plain washer is used for mounting 60# wire stands and 2 plain washers for mounting 30# stands.

MOUNTING THE UNIT

LN-9 GMA wire feeders can be mounted directly on top of their power source as long as it is secure and level. When portability is required, the LN-9 GMA can be mounted on a K163 undercarriage. See the **Accessories** section for details.

A K178-1 swivel platform is available for mounting the LN-9 GMA to the power source. See the **Accessories** section for details.

INSTALLING THE LN-9F GMA 2-ROLL AND 4-ROLL MODELS

MOUNTING THE WIRE FEED UNIT

Mount the wire feed unit by means of the insulated mounting bracket attached to the bottom of the gearbox. Refer to the LN-9F GMA Dimension Print in the **Diagrams** section of this manual for the size and location of the mounting holes. The gearbox assembly is electrically "hot" when the gun trigger is pressed. Therefore, make certain the gearbox does not come in contact with the structure on which the unit is mounted. The wire feed unit should be mounted so that the drive rolls are in a vertical plane so dirt will not collect in the drive roll area. Position the mechanism so it will point down at about a 45° angle so the wire feed gun cable will not be bent sharply as it comes from the unit.

MOUNTING THE CONTROL BOX

The same control box is used for both the 2-Roll and 4-Roll wire feed unit. It contains two keyhole slots and one slot for mounting. Refer to the LN-9F GMA Dimension Print in the **Diagrams** section of this manual for the size and location of these slots. Mount the box at some convenient location close to the wire feed unit. This will enable the 16-foot control cable assembly supplied with both the LN-9F GMA 2-Roll and 4-Roll to reach between the control box and the wire feed unit.

1. Drill the required holes in the mounting surface. Partially install 1/4-20 screws.
2. Open the control box door by removing the two door screws.
3. Mount the box.
4. Tighten the screws.
5. Close the control box door and replace the door screws.

CONNECTING THE WIRE FEED UNIT TO THE CONTROL BOX

Both the LN-9F GMA 2-Roll and 4-Roll include the same 16 ft. control and electrode cable assembly. Connect the wire feed unit to the control box as follows:

1. Make certain the cables are protected from any sharp corners that may damage their jackets. Mount the cable assembly along the boom so the end with the female amphenol connector pins is at the wire feed unit.
2. Connect the cable connector to the receptacle on the back of the wire feed unit connection box.
3. At the same end, connect the electrode lead to the connection stud of the copper strap along the side of the wire feed unit.
4. At the control box end, connect the amphenol connector of the control cable to the mating MS-type receptacle on the bottom of the control box. (See **Figure A.3**, later in this section, for the location of this connection.)

INSTALLATION

ROUTING THE ELECTRODE

The electrode supply may be either from reels, Readi-Reels, spools, or bulk packaged drums or reels. Observe the following precautions:

- The electrode must be routed to the wire feed unit so that the bends in the wire are at a minimum. The force required to pull the wire from the reel into the wire feed unit must be kept at a minimum.
- The electrode is "hot" when the gun trigger is pressed and must be insulated from the boom and structure.
- If more than one wire feed unit share the same boom, their wire and reels must be insulated from each other and insulated from their mounting structure.

See the **Accessories** section for information about mounting a K299 wire reel assembly.

ELECTRICAL CONNECTIONS - LN-9 GMA AND LN-9F GMA

POWER INPUT CABLE ASSEMBLY

A special cable assembly is required to connect all LN-9 GMA models to the power source. The assembly includes control cable and electrode cable. Various sizes are available, based on length and maximum welding current. The following power source cable assemblies are available:

K196 for Terminal Strip control connection and output terminal.

K595 for 14-Pin receptacle and output terminal.

K596 for 14-Pin receptacle and Twist-Mate" connection.

NOTE: Use of an LN-9 GMA with a Pulse Power 500, Invertec V300 or a DC650 PRO requires a K442-1 Pulse Power Filter Kit.

CONNECTING THE POWER INPUT CABLE ASSEMBLY TO THE LN-9 GMA WIRE FEED UNIT

The K196, K595, or K596 cable assembly consists of an electrode cable and multiconductor control cable. The control cable has a polarized plug on the wire feeder end. To install:

1. See Figure A.1. Connect the polarized plug of the control cable to the mating connector on the back of the wire feeder.
 2. See **Figure A.2**. Remove the screws holding the cable strain relief clamp located near the rear of the wire reel stand base. Put the control cable and the electrode cable under the clamp and install the screws.
- For cables with more than one electrode cable, leave the junction between the two or more cables and the single 4/0 stub behind the clamp so that only the single electrode lead is under the clamp.
3. See Figure A.1. Pass the single electrode cable through the hole provided in the back corner of the wire section and fasten it to the conductor block of the copper strap along the side of the wire drive unit.

FIGURE A.1 – INPUT CONTROL CABLE AND ELECTRODE CABLE CONNECTIONS

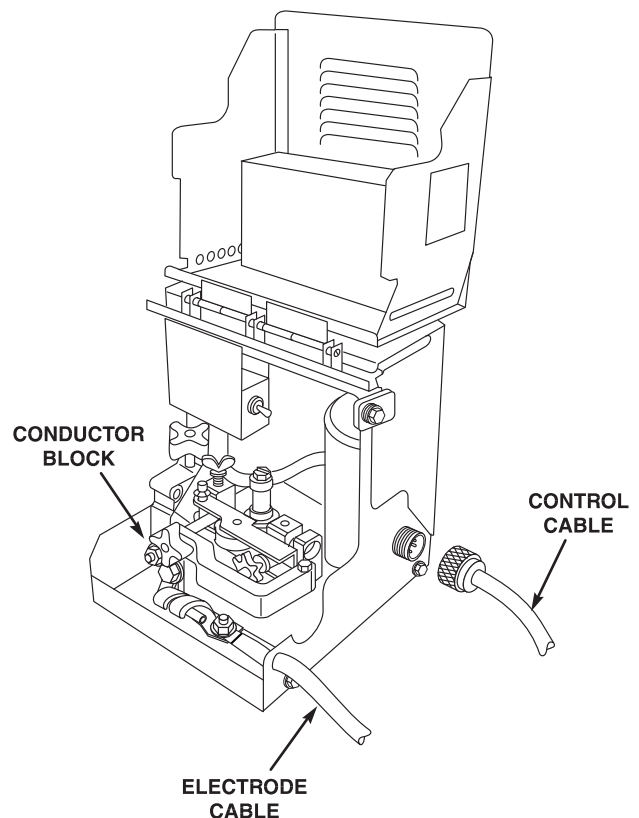

LN-9 GMA and LN-9F GMA Wire Feeder

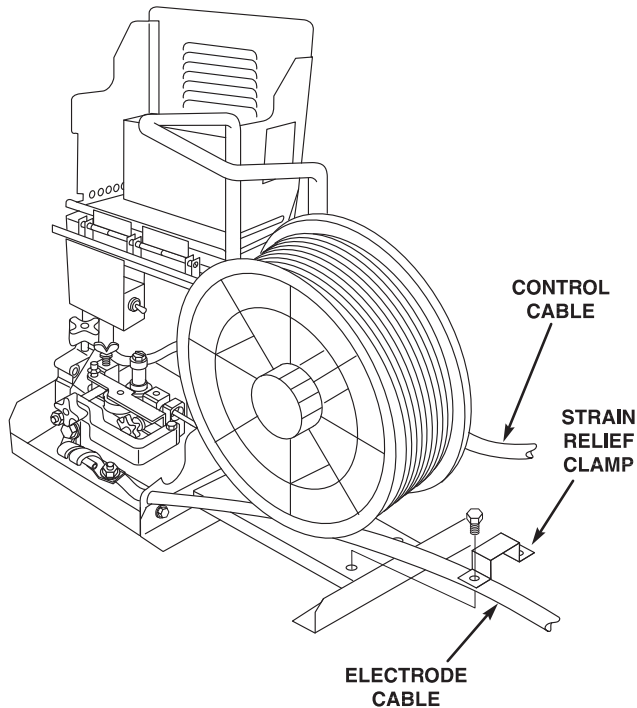
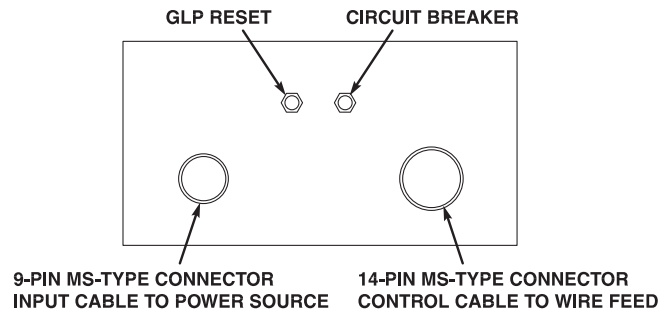

FIGURE A.2 – STRAIN RELIEF CLAMP

FIGURE A.3 – LN-9F GMA CONTROL BOX
BOTTOM VIEW

CONNECTING THE POWER INPUT CABLE ASSEMBLY TO POWER SOURCES

WARNING

Turn input supply power to the power source OFF before connecting the LN-9 GMA or LN-9F GMA wire feeder.

CONNECTING THE POWER INPUT CABLE ASSEMBLY TO THE LN-9F CONTROL BOX

1. See Figure A.3. Connect the polarized plug of the K196, K595, or K596 control cable to the mating MS-type connector on the bottom of the LN-9F GMA control box.
2. Bolt the electrode lead from the power source to the electrode lead to the wire feed unit using the nut and bolt supplied. Insulate the connection with electrical tape.

Connect to an appropriate Lincoln power source as follows:

1. If using a multipurpose source (such as the DC-250, DC-400 and DC-600), be sure it is properly set for the welding process being used. See the topic "*Making a Test Weld*," in the *Operation* section of this manual.

For terminal strip connections using the K196 power input cable, connect the input cable to the power source exactly as specified on the appropriate LN-9 GMA model connection diagram:

Figure A.4 for DC-250, DC-400 and CV-400, CV-500 I

Figure A.5 for DC-600

Figure A.6 for DC-1000

Figure A.7 for Pulse Power 500

Figure A.8 for R3S-400, R3S-600, R3S-800

INSTALLATION

Figure A.9 is a connection diagram for connecting the LN-9 GMA to V300 power sources. The connection is made with a K596 cable assembly, which has an amphenol connection rather than a terminal strip connection at the power source.

Depending on the power source and process you are using, the jumpers on the LN-9 GMA voltage board may have to be changed. As shipped, the LN-9 GMA is connected for use with the DC-250 DC-400, CV-400, CV-500-I and DC-600. For other power sources, refer to the appropriate connection diagram.

NOTE: If you are using the Pulse Power 500, DC650 Pro, or V300 power source, the K442-1 Pulse Power Filter Kit must be installed in the LN-9 GMA. See the instructions included with the kit. If you are using the Invertec V300, the K608-1 Adapter must also be installed according to the connection diagram and instructions provided in the Invertec Manual.

INSTALLATION

FIGURE A.4 – CONNECTION OF LN-9 GMA TO DC-250, DC-400, and CV/CVI POWER SOURCES

WARNING	
	<ul style="list-style-type: none"> • Turn off input power to the welding power source using the disconnect switch at the fuse box before connecting the wire feeder • Only qualified persons should install, use or service this machine.
ELECTRIC SHOCK can kill.	

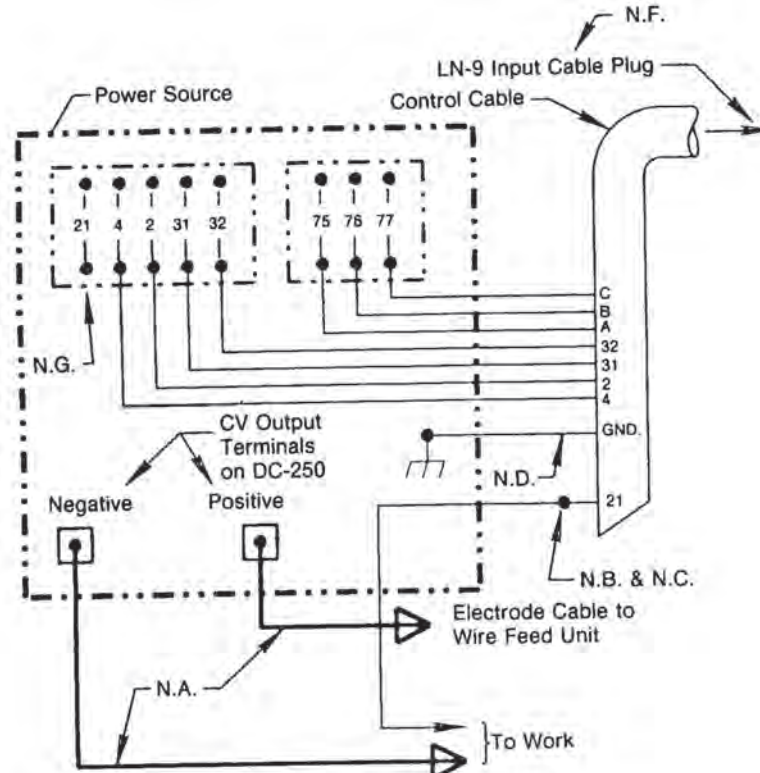



Above diagram shows electrode connected positive. To change polarity, turn power off, reverse the electrode and work leads at the power source and position the switch on power source to proper polarity.

* Does not apply to DC-400 below code 9200 with polarity switch.

N.A. Welding cables must be of proper capacity for the current and duty cycle of immediate and future applications.

N.B. Extend lead #21 using #14 AWG or larger insulated wire physically suitable for the installation. An S16586-[] remote voltage sensing work lead is available for this purpose. Connect it directly to the work piece keeping it electrically separate from the welding work lead circuit and connection. For convenience, this extended #21 lead should be taped to the welding work lead. (If the length of work lead circuit is short, and connections can be expected to be reliable, then control cable lead #21 does not need to be extended and can be directly connected to terminal #21 on the terminal strip. Note that this is not the preferred connection because it adds error to the wire feeder voltmeter reading.)

N.C. Tape up bolted connection if lead #21 is extended.

N.D. Connect the control cable ground lead to the frame terminal marked  near the power source terminal strip. The power source grounding terminal (marked  and located near the power source input power connections) must be properly connected to electrical ground per the power source operating manual.

N.F. The LN-9 GMA voltage control jumpers must be connected as follows:

White jumper on voltage board to pin "S".

Blue jumper on voltage board (later units only), or on start board (earlier units), to pin "B".

*N.G. If lead #21 is to be connected to the terminal strip, connect to the #21 terminal that matches work polarity. This connection must be changed whenever the electrode polarity is changed.

LN-9 GMA and LN-9F GMA Wire Feeder



INSTALLATION

FIGURE A.5 – CONNECTION OF LN-9 GMA TO DC-600 POWER SOURCES

WARNING	
	<ul style="list-style-type: none"> • Turn off input power to the welding power source using the disconnect switch at the fuse box before connecting the wire feeder
ELECTRIC SHOCK can kill.	<ul style="list-style-type: none"> • Only qualified persons should install, use or service this machine.

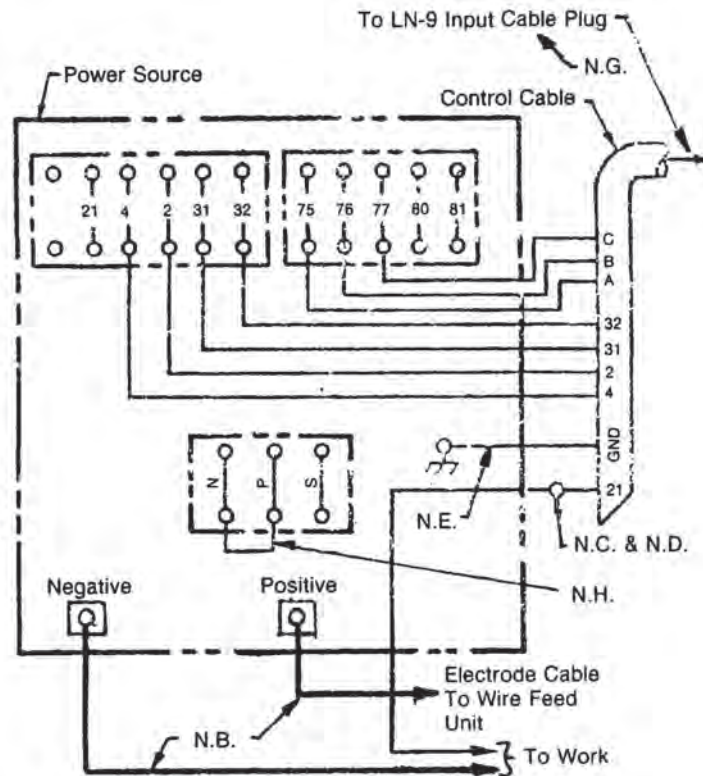

Above diagram shows electrode connected positive. To change polarity, turn power off, reverse the electrode and work leads at the power source and position the switch on power source to proper polarity.

For optimum performance with the LN-9 GMA, DC-600's with codes 8288 and above are preferred.

N.B. Welding cables must be of proper capacity for the current and duty cycle of immediate and future applications.

N.C. Extend lead #21 using #14 or larger insulated wire physically suitable for the installation. An S16586-[] remote voltage sensing work lead is available for this purpose. Connect it directly to the work piece keeping it electrically separate from the welding work lead circuit and connection. For convenience, this extended #21 lead should be taped to the welding work lead. (This extended #21 lead connection replaces the need to employ the remote work lead accessory on LN-9's which have a direct work lead jack.)

N.D. Tape up bolted connection.

N.E. Connect the LN-9 GMA control cable ground lead to the frame terminal marked  near the power source terminal strip. The power source must be properly grounded.

N.G. The LN-9 GMA voltage control jumpers must be connected as follows:

White jumper on voltage board to pin "S".

Blue jumper on voltage board (Later units only) or on start board (Earlier units) to pin "B".

N.H. For DC-600 Codes below 8200 connect a jumper from "N" to "P" on LN-9 GMA only. There is no NPS terminal strip on codes above 8200.

LN-9 GMA and LN-9F GMA Wire Feeder



INSTALLATION

FIGURE A.6 – CONNECTION OF LN-9 GMA TO DC-1000 POWER SOURCES

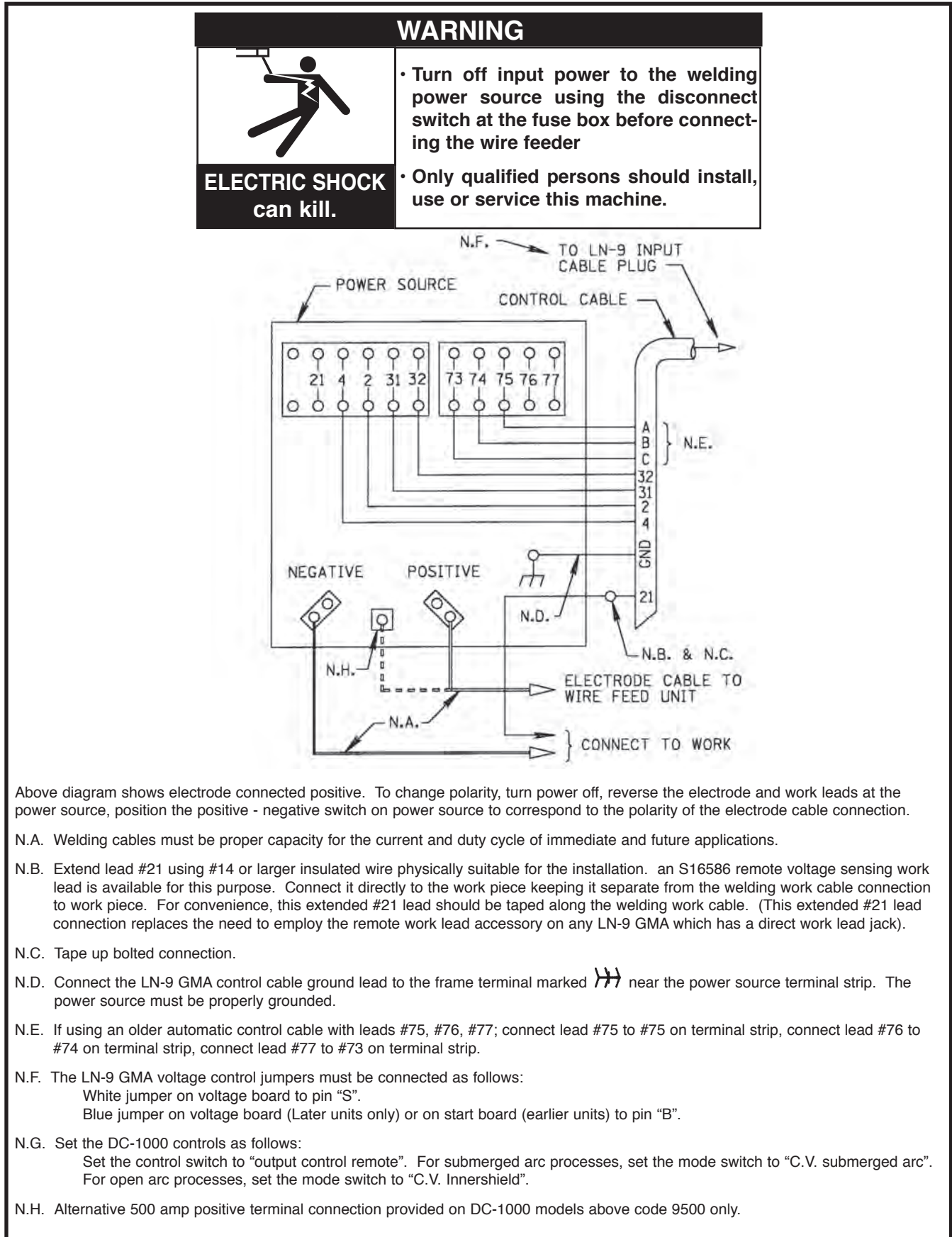

INSTALLATION

FIGURE A.7 – CONNECTION OF LN-9 GMA TO PULSE POWER 500 POWER SOURCES

WARNING	
	<ul style="list-style-type: none"> • Turn off input power to the welding power source using the disconnect switch at the fuse box before connecting the wire feeder
ELECTRIC SHOCK can kill.	<ul style="list-style-type: none"> • Only qualified persons should install, use or service this machine.

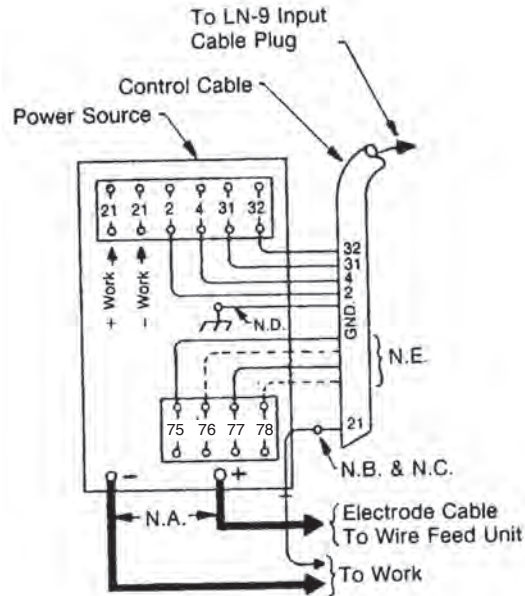



Above diagram shows electrode connected positive. To change polarity, turn power off, reverse the electrode and work leads at the power source and properly set the feeder polarity switch.

N.A. Welding cables must be of proper capacity for the current and duty cycle of immediate and future applications.

N.B. Extend lead #21 using 14 AWG or larger insulated wire physically suitable for the installation. An S16586-[] remote voltage sensing work lead is available for this purpose. Connect it directly to the work piece keeping it electrically separate from the welding work lead circuit and connection. For convenience, this extended #21 lead should be taped to the welding work lead.

N.C. Tape up bolted connection.

N.D. Connect the control cable ground lead to the frame terminal marked  near the power source terminal strip. The power source grounding terminal (marked  and located near the power source input power connections) must be properly connected to electrical ground per the power source Operating Manual.

N.E. Connect control leads to terminal strip as follows:

LN-9: A to 75 B to 77 C to 78

N.F. The LN-9 GMA voltage control jumpers must be connected as follows:

White jumper on voltage board to pin "S".

Blue jumper on voltage board is not connected to any pin. (Secure loose jumper clear of any possible interference.)

NOTE: For proper pulse welding operating with LN-9:

1. The LN-9 GMA must have an L6084-3 (or higher superseding part number) voltage board installed. (Standard above code 9100.)
2. The Pulse Power Filter board must be installed and connected in the LN-9 per instructions provided with the kit.
3. The pulse current sensor assembly (with looped copper energizer) must be installed. (Standard above code 9100.) Feeder conversion kits are available for all LN-9 GMA model codes (below 9100 and above 9100).

LN-9 GMA and LN-9F GMA Wire Feeder



INSTALLATION

FIGURE A.8 – CONNECTION OF LN-9 GMA TO IDEALARC R3S-400, R3S-600, R3S-800 POWER SOURCES

WARNING	
	<ul style="list-style-type: none"> • Turn off input power to the welding power source using the disconnect switch at the fuse box before connecting the wire feeder
ELECTRIC SHOCK can kill.	<ul style="list-style-type: none"> • Only qualified persons should install, use or service this machine.

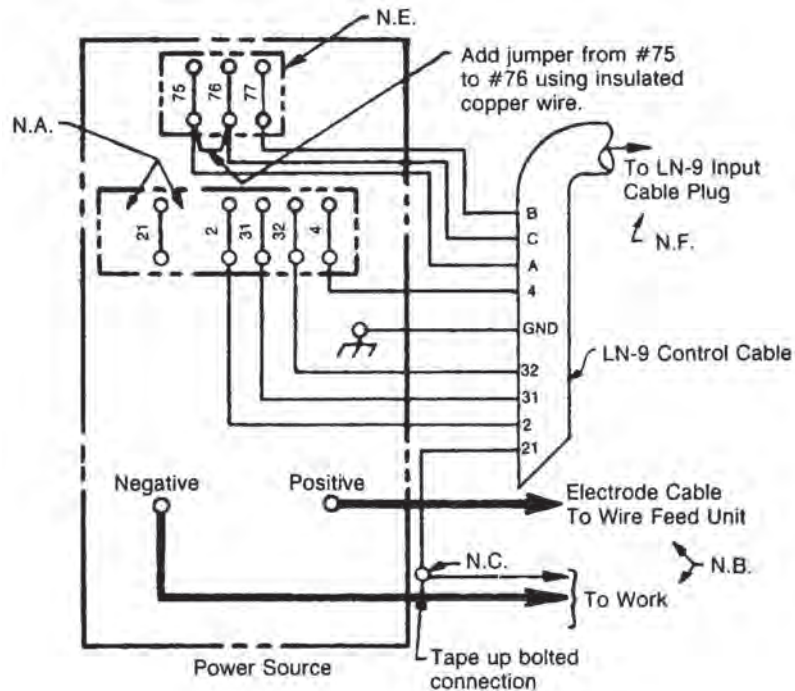

Above diagram shows electrode connected positive. To change polarity, turn power off, reverse the electrode and work leads at the power source and reverse the "control switch" at the power source, and the "polarity switch" on the LN-9 GMA.

Connect the control cable ground lead to the frame terminal marked  near the power source terminal strip or to an unpainted frame screw. The power source must be grounded properly.

N.A. On earlier R3S-400, -600 & 800 machines, #67 & #1 terminals were also on the terminal strip.

N.B. Welding cables must be of proper capacity for the current and duty cycle of immediate and future applications.

N.C. Extend lead #21 using 14 AWG or larger insulated wire physically suitable for the installation. An S16586-[] remote voltage sensing work lead is available for this purpose. Connect it directly to the work piece keeping it electrically separate from the welding work lead circuit and connection. For convenience, this extended #21 lead should be taped to the welding work lead. (This extended #21 lead connection replaces the need to employ the remote work lead accessory on LN-9's which have a direct work lead jack.)

N.E. Upper terminal strip (#75, #76 & #77) may not appear on older R3S machines, and therefore is not compatible for use since there will be no adjustment of voltage by the LN-9 GMA.

N.F. The LN-9 GMA voltage control jumpers must be connected as follows:

White jumper on voltage board;

To pin "F" for open arc process or

To pin "S" for submerged arc process.

Blue jumper on voltage board (later units only), or on start board (earlier units), to pin "A".

LN-9 GMA and LN-9F GMA Wire Feeder



INSTALLATION

FIGURE A.9 – CONNECTION OF LN-9 GMA TO V300 POWER SOURCES

WARNING	
	<ul style="list-style-type: none"> • Turn off input power to the welding power source using the disconnect switch at the fuse box before connecting the wire feeder • Only qualified persons should install, use or service this machine.
ELECTRIC SHOCK can kill.	

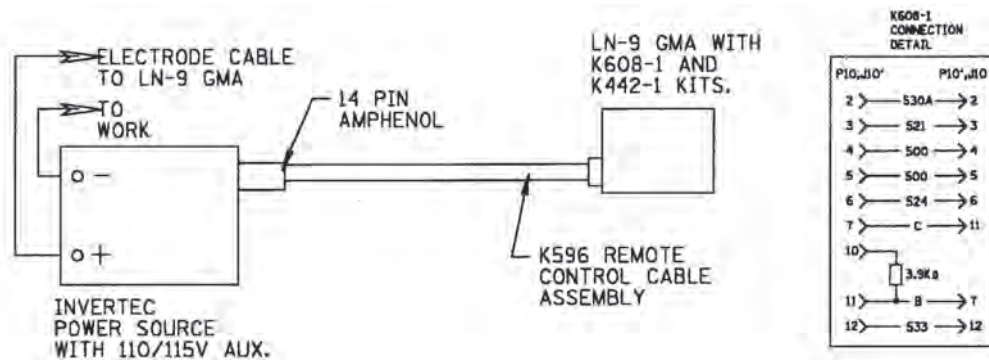

N.A. Welding cable must be sized for current and duty cycle of application.

N.B. Diagram shows electrode positive. To change polarity, turn power "OFF", reverse electrode and work cable at power source. Set meter polarity switch on rear of invertec to coincide with polarity used. Set LN-9 GMA polarity switch also.

N.C. Install K608-1 adapter in line with P10 to LN-9 GMA voltage board and secure to adjacent harness with wire tie provided. Turn "start" trimmer on voltage board per instructions in V300 manual.

N.D. For GMAW welding, install Pulse Power Filter Kit K442-1 in LN-9 GMA.

LN-9 GMA and LN-9F GMA Wire Feeder



INSTALLATION

MACHINE GROUNDING

LN-9 GMA wire feeders are grounded to the power source through the input cable. The power source grounding cable must be properly connected to electrical ground. See your power source operating manual for details.

WORK CABLE CONNECTION

Connect a work lead of sufficient size and length between the proper output terminal on the power source and the work. See Table A-1. Be sure the connection to the work makes tight metal-to-metal electrical contact. Poor work lead connections can activate the grounding lead protector and/or result in poor welding performance.

TABLE A.1 – WORK CABLE SIZES

Current 60% Duty Cycle	Copper Work Cable Size, AWG	
	Up to 50' length	50'-100' length
300 Amps	0	00
400 Amps	00	000
500 Amps	00	000
600 Amps	000	0000

DIRECT WORK LEAD CONNECTION

Lincoln specified procedures give voltage readings taken between the work and the gun cable brass connection block of the LN-9 GMA. To match these voltage readings, the connection diagrams show the #21 lead being extended and connected directly to the work instead of #21 on the power source terminal strip (or Dual Process Kit terminal strip). This extended lead must be connected directly to the work. When using a Dual Process Kit, you must extend the lead individually for each LN-9 GMA.

As an alternative, LN-9 GMA models are provided with a quick-connect terminal splice connection in the #21 lead between the input Amphenol connector of the LN9 GMA and its polarity switch. See the LN-9 GMA wiring diagram. This in-line connection consists of a red insulated male and female .250 x .032 terminal pair located in the lead harness. It runs along the right side of the wire feed motor inside the control section of the LN-9 GMA models and in the lead harness at the lower left corner of the control box (near the input Amphenol) of the LN-9F models. You may also open this #21 lead and connect your own direct work lead equipped with a .250 x .032 female quick-connect terminal to the male side of the splice. This direct work lead connection must be tape insulated, strain-relieved, and routed outside the LN-9 GMA control box to be connected directly to the work.

With either direct work lead connection method, the LN-9 GMA regulates the power source to hold the arc voltage constant, even with voltage drops in the electrode lead, work lead, or work lead connection. If the direct work lead becomes disconnected from the work, the LN-9 GMA wire feeder will stop welding shortly after the arc is struck. See the topic "**Circuit Protection and Automatic Shutdown**" in the **Operation** section of this manual.

CONNECTING THE GUN CABLE TO THE WIRE FEEDER

A variety of gun and cable assemblies are available for the LN-9 GMA models. See the **Accessories** section of this manual.

Lay the cable out straight. Insert the connector on the welding conductor cable into the brass conductor block on the front of the wire drive unit. See Figure A.10. Make sure the connector is fully seated and tighten the plastic thumbscrew. Keep this connection clean and bright. Connect the control cable polarized Amphenol plug into the mating 5-cavity receptacle on the front panel of the wire drive section.

FOR GMA GUN CABLES:

Install the barbed fitting and union nut to the 5/8-18 female inert gas fitting on the front of the LN-9 GMA wire drive section. Connect the 3/16" I.D. gas hose from the gun cable to the barbed fitting.

When you remove the gun, you can easily detach this fitting by loosening the union nut.

FIGURE A.10 – GUN CABLE CONNECTIONS

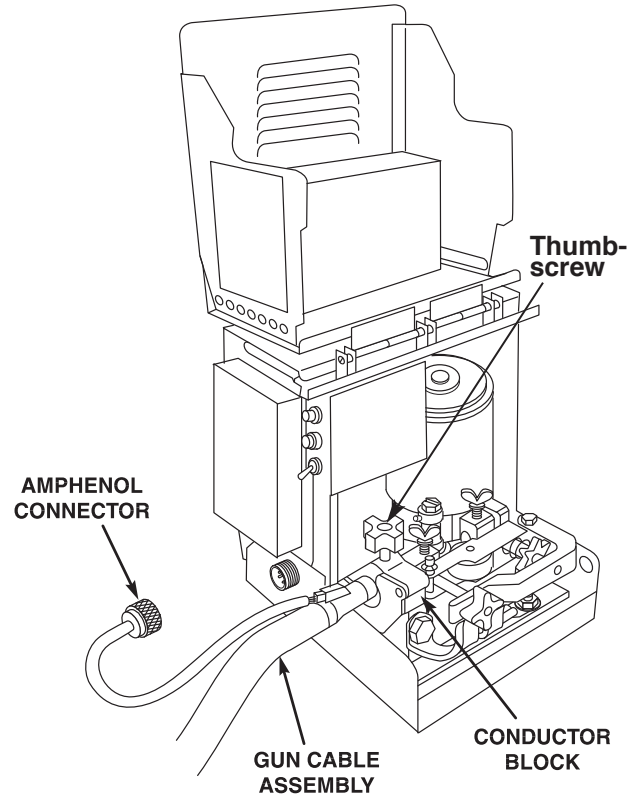

INSTALLATION

HOOKING UP GMA SHIELDING GAS

WARNING



CYLINDER may explode if damaged.

- Gas under pressure is explosive.
- Always keep gas cylinders in an upright position and always keep them chained to the undercarriage or a stationary support.

See American National Standard Z-49.1, "Safety in Welding and Cutting," published by the American Welding Society.

The user must provide a cylinder of shielding gas, a pressure regulator, a flow control valve and a hose from the flow valve to the gas inlet fitting of the LN-9 GMA. See Figure A.11 and install as follows:

1. Connect the supply hose from the gas cylinder flow valve outlet to the 5/8-18 female inert gas fitting on the back panel of the LN-9 GMA wire drive section.
2. Install the barbed fitting and union nut to the 5/8-18 female inert gas fitting on the front of the LN-9 GMA. Connect the 3/16 inch (4.8 mm) I.D. gas hose from the gun to the barbed fitting.

When you need to remove the gun, you can easily detach this fitting by loosening the union nut.

FIGURE A.11 – SHIELDING GAS HOOKUP

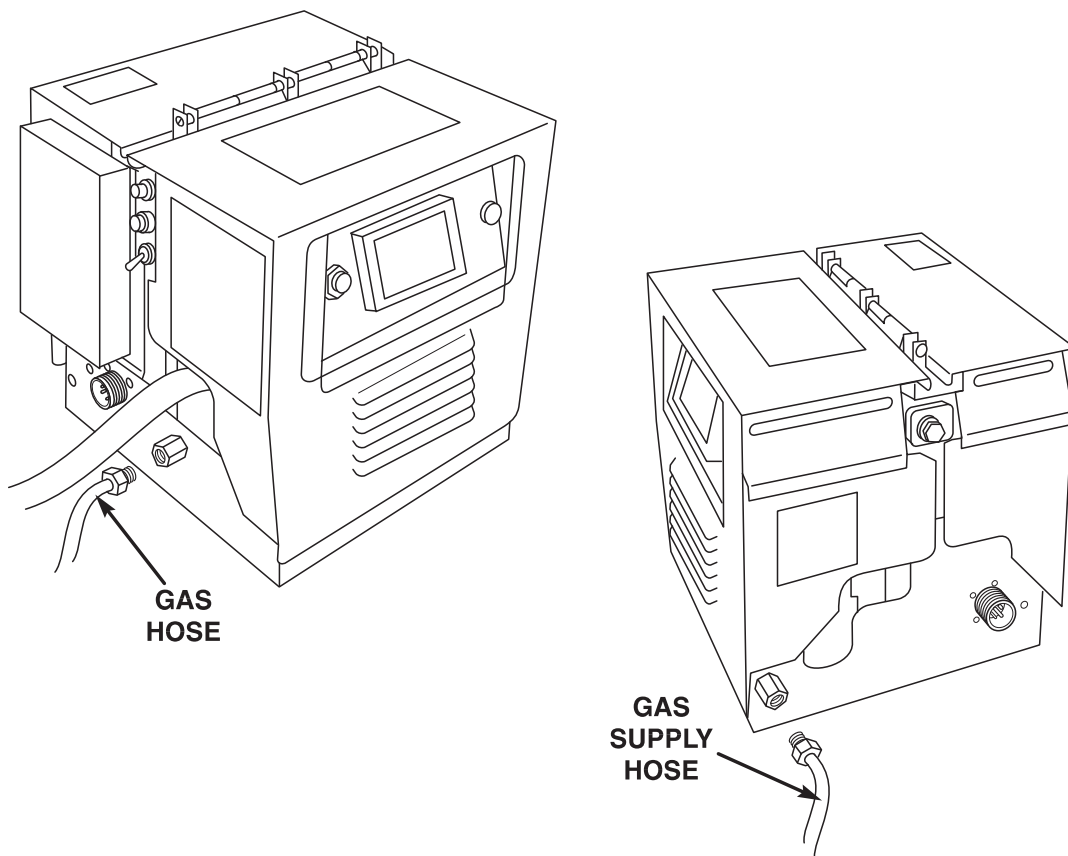

LN-9 GMA and LN-9F GMA Wire Feeder



OPERATING INSTRUCTIONS

Read and understand this entire section of operating instructions operating the machine.

SAFETY PRECAUTIONS

WARNING



ELECTRIC SHOCK can kill.

- Do not touch electrically live parts such as output terminals or internal wiring.
- Insulate yourself from the work and ground.
- Always wear dry insulating gloves.



FUMES AND GASES can be dangerous.

- Keep your head out of fumes.
- Use ventilation or exhaust to remove fumes from breathing zone.



WELDING SPARKS can cause fire or explosion.

- Keep flammable material away.



ARC RAYS can burn.

- Wear eye, ear, and body protection.

OPERATION

GENERAL DESCRIPTION

The LN-9 GMA 2-Roll and 4-Roll semiautomatic wire feeder models feature the precise "set and forget" digital procedure control and the other welding and operator features pioneered by the original LN-9 models. In addition, the LN-9 GMA models also have the following advantages for small wire gas metal arc welding with solid or flux cored Outershield® electrodes:

- High speed wire drive with a high torque permanent magnet motor and tool-less "quickrelease" idle roll pressure arms, guide tubes and gun cable fastening.
- Factory installed gas solenoid valve with gas inlet and outlet fittings.
- Adjustable preflow, postflow and burnback timers. Purge and cold inch switch functions are available.
- For 4-Roll models, a design which provides the additional feeding force. This is required when using gun cables over 15 ft. long or when wire is being pulled long distances (for example, bulk packages). Because the 4-Roll feeder has twice the contact surface, it can also help when feeding softer wires. It delivers the same or more feeding force as the 2-Roll with less overall wire deformation. Wire size range, speed and features are the same as other LN-9 GMA models.

RECOMMENDED PROCESSES AND EQUIPMENT

The LN-9 GMA is available in four models:

K424 LN-9 GMA 2-ROLL AND K568-1 LN-9 GMA 4-ROLL

Wire feed unit and all controls completely enclosed in a single portable enclosure. See Figure B-1.

FIGURE B.1 – BASIC LN-9 GMA HOOKUP

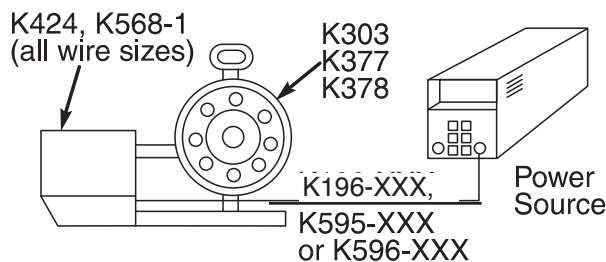

K436 LN-9F GMA 2-ROLL AND K583-1 LN-9F GMA 4-ROLL

Separate wire feed unit and control box with 16 ft cable assembly for boom or fixture mounting. See Figure B.2.

FIGURE B.2 – BASIC LN-9F GMA HOOKUP

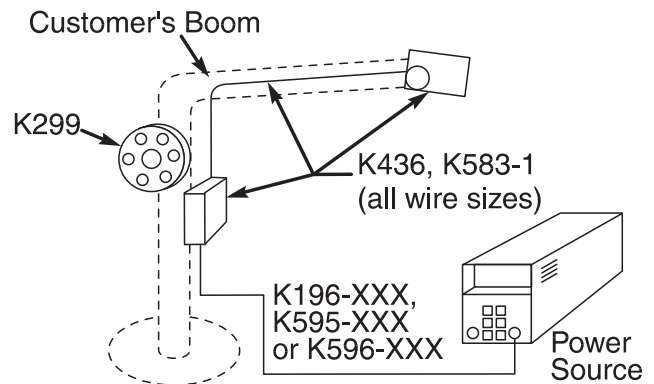

When combined with the broad selection of quality welding equipment and accessories, the LN-9 GMA provides a versatile precision welding system to meet the specific needs of gas metal arc and Innershield® or submerged arc welding processes. The capabilities of the LN-9 GMA 2-Roll and 4-Roll are:

Rated wire size range:

- .023 through 1/16 solid wire electrode.
- .045 through 5/64 Outershield® cored electrode.
- .062 through 5/64 Innershield® cored electrode.

Rated wire speed range:

- 80 through 980 inches per minute.
- (2.03 through 24.9 meters per minute).

DC CONSTANT VOLTAGE POWER SOURCES

The following welding system power sources are available for use with all LN-9 GMA models:

The Idealarc® DC-250, DC-400, CV-400, CV-500 and DC-600 are recommended for use with any LN-9 GMA model, as well as the Pulse Power 500, Invertec V300, and DC650 Pro, with the installation of the optional K442-1 Pulse Power Filter Kit.

R3S-400 and R3S-600 may also be used, but are limited due to narrow voltage range on each tap. They are not recommended if input voltage varies.

OPERATION

CONTROLS AND SETTINGS

Operator controls for LN-9 GMA models are shown in Figure B.3. Controls for LN-9F models are shown in Figure B.4. Refer to these figures and the following descriptions of the controls.

ELECTRODE POLARITY SWITCH: The polarity switch is located inside the wire drive section on the LN-9 GMA model and on the front panel of both the LN-9F GMA 2-Roll and 4-Roll control box. Set the switch to the same polarity as the electrode lead connection to the power source. If the switch is not set for the correct polarity, the wire feeder will stop welding shortly after the arc is struck. See the topic "**Automatic Shutdown**" later in this section of the manual.

WIRE FEED DIRECTION SWITCH: The direction switch is located inside the wire drive section on the LN-9 GMA model and on the front panel of both the LN-9F GMA 2-Roll and 4-Roll control box. This switch permits the wire to be fed in either direction when the trigger is pressed or when using the cold inch switch feature of the K418 and K419 options. Be sure this switch is set for forward feed when you are ready to weld.

HOT-COLD TRIGGER INTERLOCK SWITCH: This switch is located on the front rail on the LN-9 GMA model and on the front panel of both the LN-9F GMA 2-Roll and 4-Roll control box. The three-position switch serves a dual purpose:

1. **"Hot-Cold" Wire Feed** - In the center position the wire will be electrically cold when feeding with the gun trigger. In either the up or down positions the wire will be "hot" when feeding with the gun trigger.
2. **Trigger Interlock Function** - In the down position the trigger interlock will be OFF, allowing the gun trigger to function in the normal mode. This stops wire feed and welding when the trigger is released. In the up position the trigger interlock will be ON. The trigger interlock feature functions as follows:
 - a) When you are not welding, the trigger will function in the normal mode, which feeds only when the trigger is closed.
 - b) Once the welding arc has been struck, the gun trigger may be released. Welding will continue until one of the following occurs:
 - The arc is extinguished by quickly pulling the gun away from the work.
 - or
 - The trigger is again depressed and released. (This feature is not on earlier versions unless the L7265-1 PM Power Board has been replaced with a superceded version.)

OPERATION

FIGURE B.3 – WIRE FEEDER CONTROLS FOR LN-9 GMA

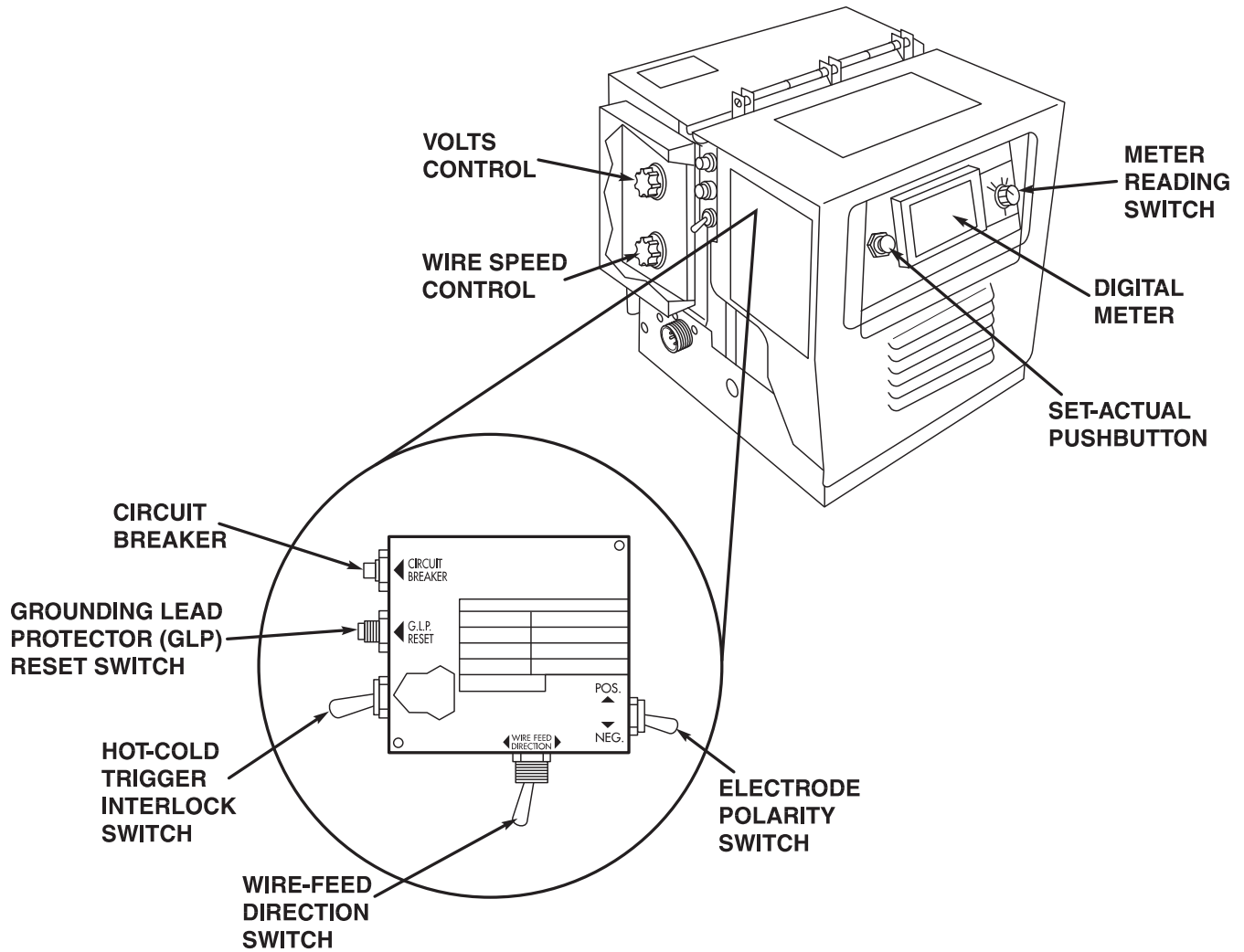

LN-9 GMA and LN-9F GMA Wire Feeder



OPERATION

FIGURE B.4 – WIRE FEEDER CONTROLS FOR LN-9F GMA

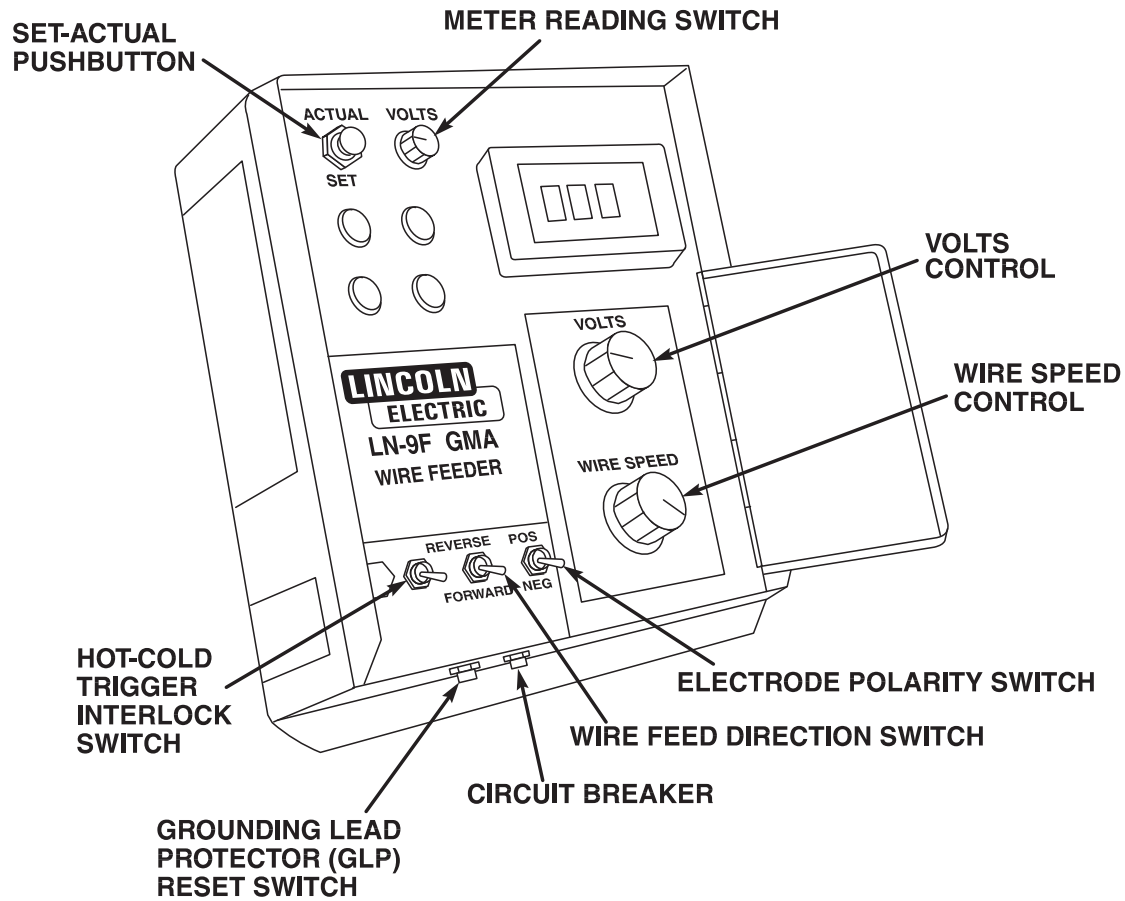

GROUNDING LEAD PROTECTOR (GLP) RESET SWITCH

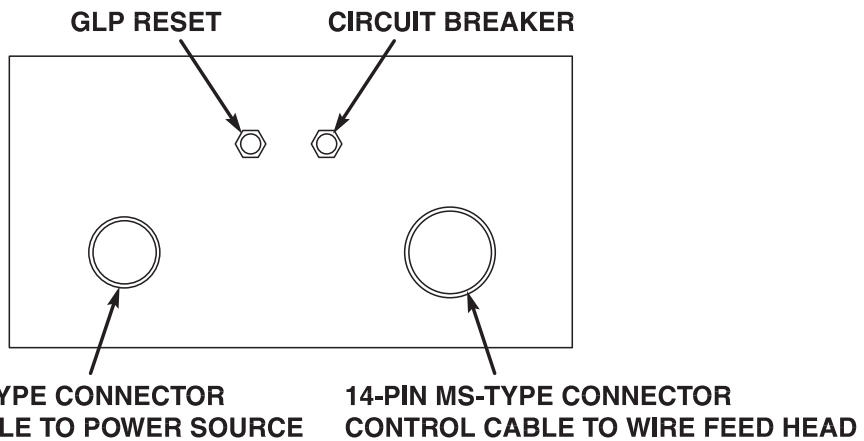

LN-9F GMA CONTROL BOX BOTTOM VIEW

LN-9 GMA and LN-9F GMA Wire Feeder



OPERATION

CIRCUIT BREAKER AND GROUNDING LEAD PROTECTOR (GLP) RESET SWITCH: These protection circuit devices are located on the front rail of the LN-9 GMA model and bottom panel of the LN-9F models. See the topic "***Circuit Protection and Automatic Shutdown***" later in this section of the manual.

DIGITAL METER: A three-digit digital meter is provided to set and monitor the welding procedure. The arc voltage is displayed in volts and the wire feed speed is displayed in inches/minute or meters/minute.

METER READING SWITCH, VOLTS AND WIRE SPEED CONTROLS: This four-position rotary switch is located to the right of the digital meter on LN-9 GMA models and to the left of the digital meter on LN-9F models. When set to the "Volts" position, the meter reads the arc voltage setting as adjusted by the "Volts" control. The rated setting range for all the LN-9 GMA models is 12.0 to 60.0 volts.

The three "Wire Speed" positions include an English position, for meter readings in inches/minute; and "LO" and "HI" range metric positions for meter readings in meters/minute. The wire feed speed setting is adjusted by the "Wire Speed" control. The rated setting range for all the LN-9 GMA models are 80 to 980 inches/minute (2.03 to 24.9 meters/minute).

When using metric meter readings, set the switch to "LO" for more precise meter readings up to 393 in/min (9.99 m/min.). For higher wire feed speeds, the "LO" position will result in an over-range meter reading of E.EE which indicates that the "HI" range, with single decimal place resolution, should be used. Similarly, EEE will be displayed on the English position if the setting exceeds 999 inches/minute.

The procedure adjustments can be made before or during the weld. This feature permits the operator to set the welding voltage and wire speed before welding and without assistance.

Once set, the control circuits of the LN-9 GMA will continuously monitor the volts and wire speed and correct any deviation from the set value so there will be negligible change.

Should the range of the power source output voltage be such that the unit circuit cannot keep the arc voltage as set, the unit will stop welding shortly after the arc is struck. See the topic "***Circuit Protection and Automatic Shutdown***" later in this section of the manual.

SET-ACTUAL PUSHBUTTON: After the weld has been started, the ACTUAL voltage or wire speed can be read by pressing the pushbutton to the left of the meter. The METER READING switch must be set in the desired position. When the pushbutton is not being operated, the meter continues to read the SET value.

CIRCUIT PROTECTION AND AUTOMATIC SHUTDOWN

CIRCUIT BREAKER

The circuit breaker normally trips only when excessive loading in the wire feed cable or a defective motor or control component causes an overload. After allowing a minute for cooling, push in the circuit breaker button and weld. If it trips again, be sure the wire feed cable is clean and the proper size for the wire diameter being fed. If the breaker still trips, look for a defective electrical component. When the circuit breaker is tripped, the digital meter is off and the trigger circuit will not operate.

POWER SUPPLY FUSE

The fuse on the PM power board inside the control box protects the power supply circuit. When the fuse is blown, the digital meter is off and the trigger circuit will not operate.

VOLTAGE PC BOARD FUSE

The 1/8 amp fast-blow fuse protects the LN-9 GMA circuitry from damage that may result from a ground, or case, faulted control lead. If this fuse blows, the LN-9 GMA arc voltage sensing lead circuit will be opened. See the topic "***Automatic Shutdown***" below.

AVOIDING GROUNDING LEAD PROTECTOR (GLP) SHUTDOWN

The frames of all LN-9 GMA wire feed units and drive motors are grounded to the frame of the power source by a lead in the control cable. An overload protector prevents welding current from damaging this lead if the electrode circuit touches the wire feeder frame while the gun trigger is pressed.

OPERATION

If such a grounding lead fault occurs, the meter will still be on and will be reading. The trigger circuit will not operate, however. To release the circuit, press the "GLP Reset" button. See **Figure B.3 or B.4** for the location of this button.

The following precautions are recommended to avoid GLP shutdown:

- Do **not** allow the electrode to contact the case of the wire feeder or uninsulated part of its wire reel stand when the gun trigger is activated.
- Be sure that all work lead connections to the work make tight metal-to-metal electrical contact.
- Do **not** allow excess input cable or work cable to be placed closer than 3 feet to the wire feeder.
- Do **not** coil excess input cable assembly or use an uncoiled assembly as shipped from the factory. Instead, loop excess length back and forth in 3 to 6 foot straight lengths. Coiling the input cable results in a transformer action between the electrode conductor cable and ground lead in the multiconductor cable and the ground lead in the multiconductor control cable. This can cause current to flow in the ground lead, which will falsely activate the GLP.

AUTOMATIC SHUTDOWN

If the LN-9 GMA voltage control is unable to supply the SET value of arc voltage while welding, the automatic shutdown circuit will activate. This protection circuit immediately returns the LN-9 GMA control to idle state within a few seconds after the arc voltage discrepancy occurs.

Typical causes for the activation of this protective shutdown circuit are as follows:

- a) SET value of arc voltage is outside the power source range.
- b) Power source voltage control not set for REMOTE.
- c) Misconnection of LN-9 control cable leads to power source.
- d) Incorrect weld polarity connections, or settings, at the LN-9 GMA or the power source.
- e) Lost connection of LN-9 GMA voltage sensing leads (#67 and #21) between the arc and voltage control, or a blown 1/8 amp fuse on the Voltage PC board.

In the case of full range control power sources, such as the DC-600, this protective shutdown circuit could prevent welding under the conditions of (c), (d), and (e) above by holding the power source output at minimum. The power source output might even be too low to establish an arc.

Although out of range shutdown can occur with all power sources when working with very low or very high arc voltages, it is most likely to occur when using the R3S models with somewhat limited voltage range of the various taps. For instance, if the R3S-400 triangle tap setting is for 31 volts, the range of control from the remote circuit is approximately 7 volts, i.e., 27-1/2 to 34-1/2 volts at nominal input voltage. If the LN-9 GMA controls are set for 29 volts and the input voltage to the R3S goes up, it may not be possible for the LN-9 GMA control circuit to hold the 29 volts. The welding will shut down. By changing to the 27 volt triangle setting, the range will be approximately 23-1/2 to 30-1/2 volts, and at high input voltage there will be sufficient control to hold the SET arc voltage.

The same general procedure can be used on other power sources. For example, if the LN-9 GMA keeps shutting down and the other possible causes have been checked, adjust the SET voltage higher and/or lower than the desired voltage. Then you can determine what change in the range controls of the power source is required to supply the desired voltage.

In some cases, it is also possible to hold the ACTUAL button pressed while starting the arc. Before the LN-9 GMA shuts down, the actual arc voltage can be read on the digital meter. Comparing this reading to the SET reading will tell what change in the range controls of the power source is required to supply the desired voltage. Should the meter read zero, check the connections of LN-9 GMA sensing leads #21 and #67. Should the meter read a minus (-) voltage, the polarity connections or settings at the LN-9 GMA or power source are wrong.

DRIVE ROLL INSTALLATION

CHANGING DRIVE ROLLS FOR 2-ROLL WIRE FEEDERS

To change drive rolls on a 2-roll wire feeder, refer to **Figure B.5** and perform the following steps.

NOTE: Although an LN-9 GMA model is shown in Figure B.5, the following procedure also applies to LN-9F GMA models.

1. Rotate the latch knob on the quick release arm.
2. Remove the hex head screw and clamping collar. Remove the drive roll from the shaft. On new machines, remove the tape and the drive key.
3. The new roll to be installed is stamped for the size to be fed. An "A" after the size indicates aluminum wire. Remove the rolls from the kit and wipe them clean. Wipe the output shaft and locating shoulder clean.
4. Use the drive key, clamping collar, and hex head screw to install the roll on the output shaft. Certain size drive rolls consist of two roll halves, and may contain a spacer. If the drive roll you are installing contains a spacer, the spacer fits between the two halves of the drive roll. Tighten the hex head screw.
5. Back out the guide tube clamping screws. Remove the old guide tubes, if installed.
6. Insert the outgoing guide tube (the one with the plastic insert) into the front hole. If the guide tube has a non-symmetrical chisel end, the larger radius must face the drive roll. See **Figure B.5**. Push the guide tube back as far as it will go and tighten the clamping screw. Insert the incoming guide tube as far back as it will go and tighten the clamping screw. The clamping screws are dog points. When the guide tubes are properly installed these dog points will lock into the annular grooves in each of the guide tubes.
7. Set the idle roll pressure as detailed in the **Idle Roll Pressure Setting** procedure detailed later in this section.

OPERATION

FIGURE B.5 – INSTALLING DRIVE ROLLS ON A 2-ROLL FEEDER

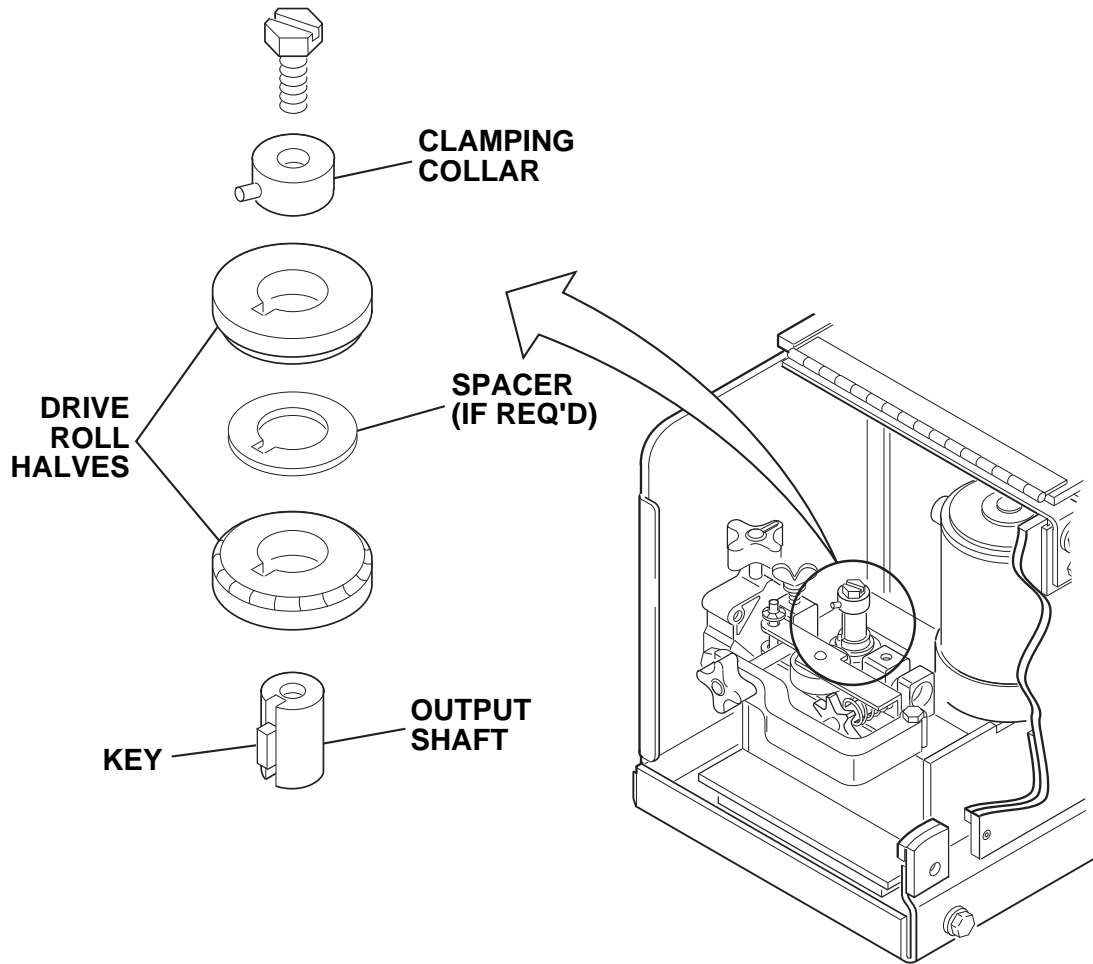

GUIDE TUBE DETAIL

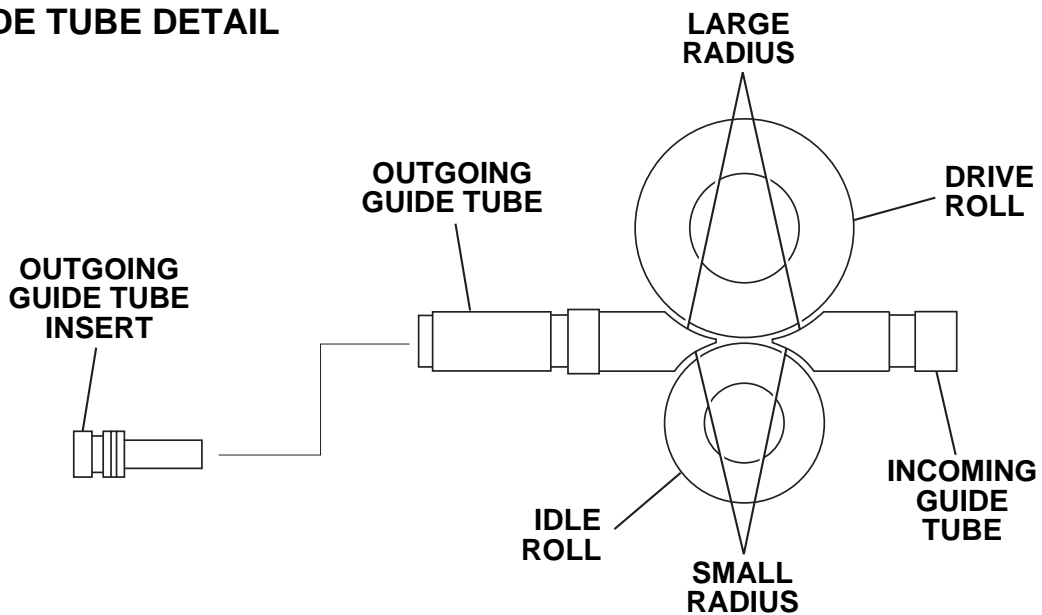

LN-9 GMA and LN-9F GMA Wire Feeder



CHANGING DRIVE ROLLS FOR 4-ROLL WIRE FEEDERS

To change drive rolls on a 4-roll wire feeder, refer to **Figure B.6** and perform the following steps.

NOTE: Although an LN-9 GMA model is shown in **Figure B.6**, the following procedure also applies to LN-9F GMA models.

1. Remove the gun and cable from the conductor block on the feeder by loosening the hand screw and pulling the gun straight out of the block.
2. Open both quick release levers by moving the levers outward and pulling them toward you.
3. Loosen the thumb screws holding the guide tubes in place. Remove the incoming and outgoing guide tubes, if installed.
4. Remove the hex head screws and clamping collars from the output shafts. Remove the drive rolls and middle guide tube, if installed. On new feeders remove the tape and drive keys.
5. The new rolls to be installed are stenciled with the wire size that will be fed. An "A" after the number indicates aluminum wire. Remove the rolls from the kit and wipe them clean. Wipe the output shafts and locating shoulders clean.
6. Install one roll onto either output shaft using the drive key, clamping collar, and hex head screw. Certain size drive rolls consist of two roll halves, and may contain a spacer. If the drive roll you are installing contains a spacer, the spacer fits between the two halves of the drive roll. Tighten the hex head screw.
7. Install the middle guide tube, but do not tighten at this time. When installing a 0.035" middle guide tube the larger radius should be aligned towards the drive roll. Slide the guide tube up against the drive roll.
8. Install the second drive roll on the remaining shaft the same way as the first. Center the middle guide tube between the rolls and tighten the thumb-screws holding it in place.
9. Close and latch both quick release levers.
10. Slide the incoming guide tube into the rear hole of the gearbox until it almost touches the drive roll and guide tube. Tighten the thumbscrew to hold it in place.
11. Install the outgoing guide tube into the front hole of the gearbox (through the conductor block) and tighten the thumb screw. The 0.035 in. outgoing guide tube should have the larger radius oriented toward the drive roll. For proper installation of the outgoing guide tube insert, refer to **Figure B.6**.
12. Be certain that the guide tubes do not touch the drive rolls or idle rolls. If they do touch, readjust them and tighten in place.

OPERATION

FIGURE B.6 – INSTALLING DRIVE ROLLS ON A 4-ROLL FEEDER

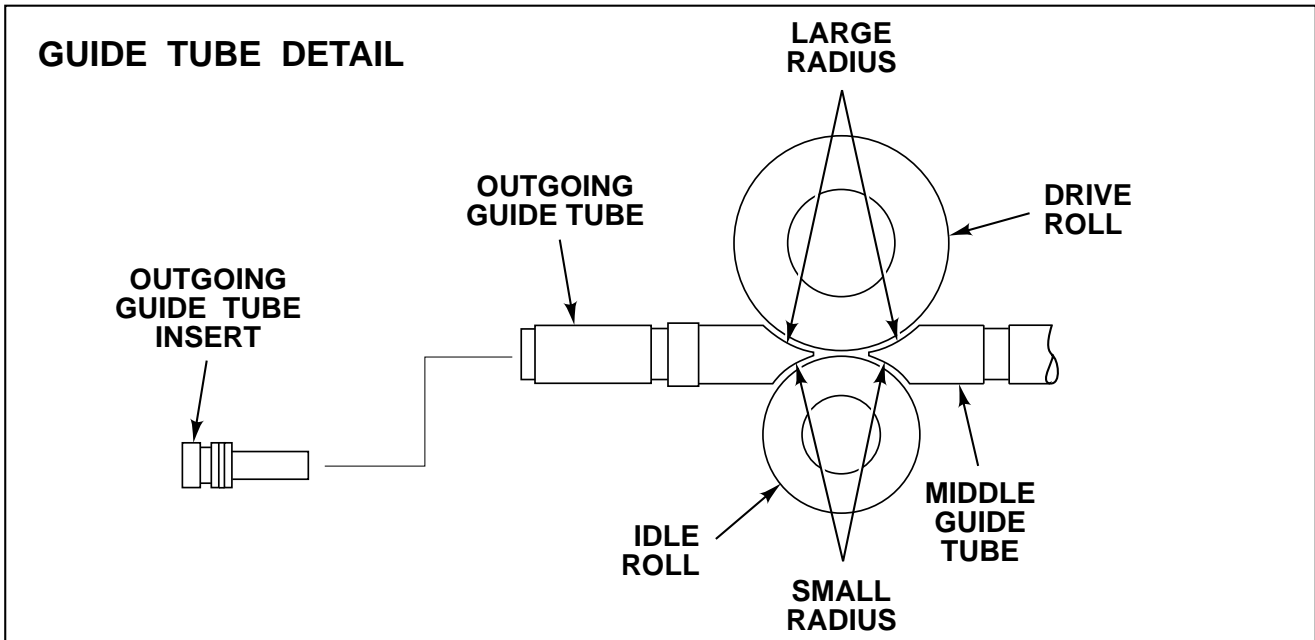
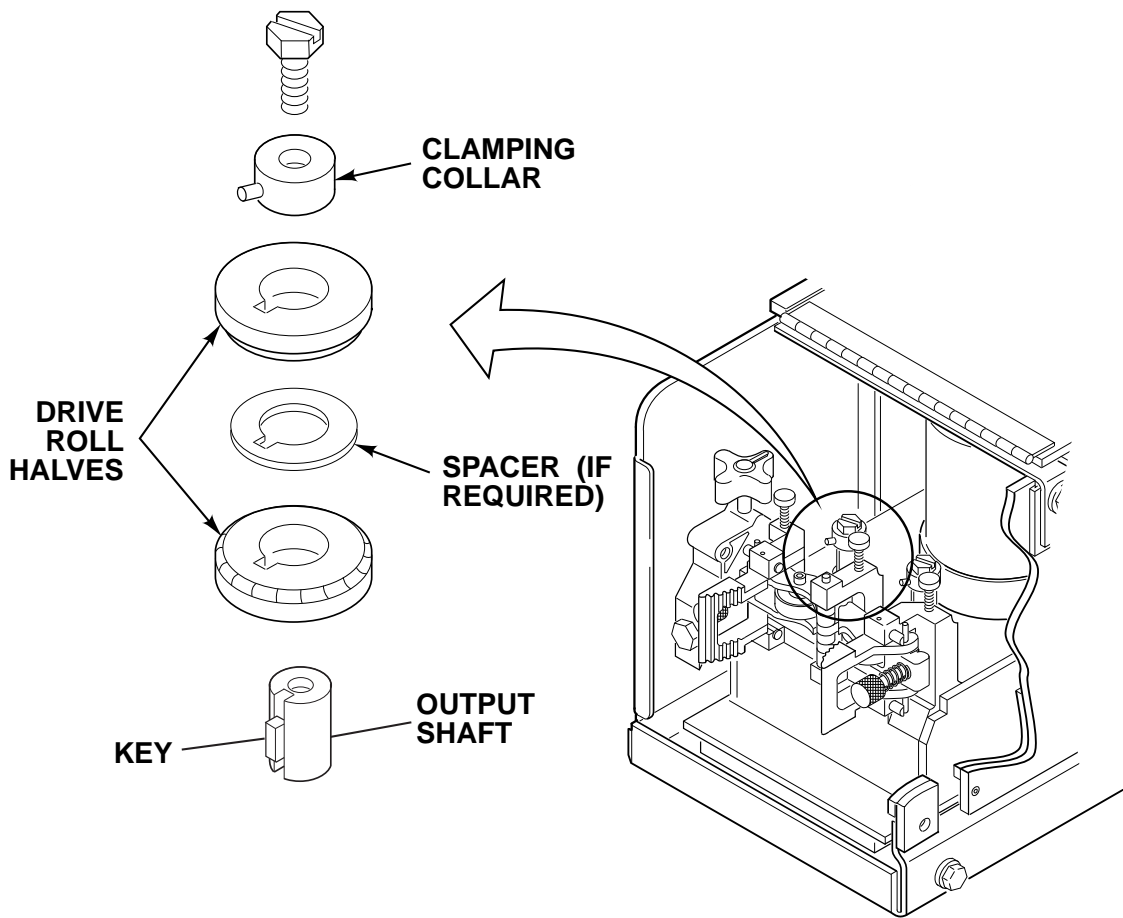

LN-9 GMA and LN-9F GMA Wire Feeder



OPERATION

WIRE LOADING

Loading a 22 to 30 Lb. (10 to 14 kg) REDI-Reel Package Using the Molded Plastic K363-P REDI-Reel Adapter:

The Spindle should be located in the **LOWER** mounting hole.

- 1) Depress the Release Bar on the Retaining Collar and remove it from the spindle. **NOTE:** Earlier spindles used a threaded collar. See Figure B.7a or B.7b.
- 2) Place the Adapter on the spindle.
- 3) Re-install the Retaining Collar. Make sure that the Release Bar “pops up” and that the collar retainers fully engage the retaining groove on the spindle.
- 4) Rotate the spindle and adapter so the retaining spring is at the 12 o'clock position.
- 5) Position the REDI-Reel so that it will rotate in a direction when feeding so as to be de-reeled from the bottom of the coil.
- 6) Set one of the REDI-Reel inside cage wires on the slot in the retaining spring tab.
- 7) Lower the REDI-Reel to depress the retaining spring and align the other inside cage wires with the grooves in the molded adapter.
- 8) Slide the cage all the way onto the adapter until the retaining spring “pops up” fully.

⚠ WARNING

Check to be sure the Retaining Spring has fully returned to the locking position and has **SECURELY** locked the REDI-Reel Cage in place. Retaining Spring must rest on the cage, not the welding electrode.

- 9) To remove REDI-Reel from Adapter, depress retaining spring tab with thumb while pulling the REDI-Reel cage from the molded adapter with both hands. Do not remove adapter from spindle.

FIGURE B.7a (Threaded Locking Collar)

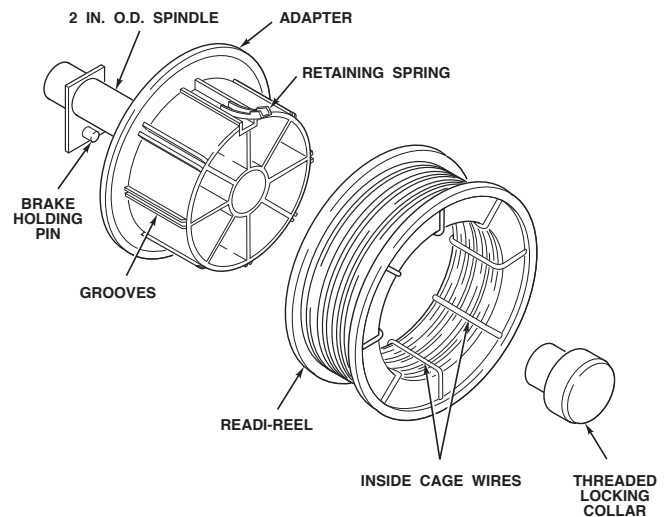
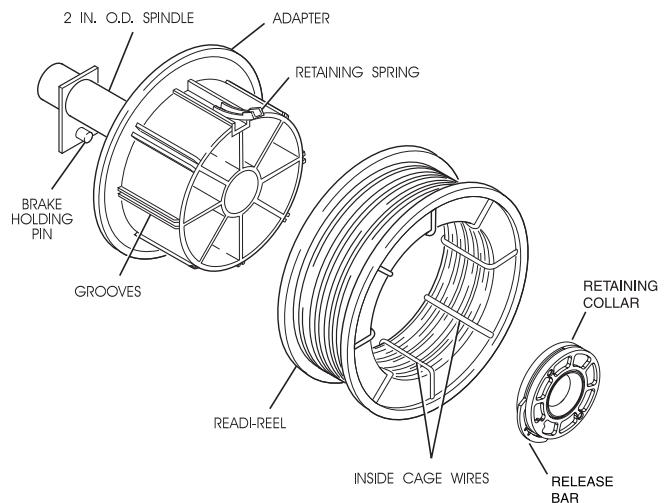

FIGURE B.7b (Retaining Collar)



OPERATION

LOADING A 10 TO 30 LB. (4.5 TO 14 KG) SPOOL (12" DIAMETER) OR 13 - 14 LB. (6 KG) INNERSHIELD COIL:

The Spindle should be located in the **LOWER** mounting hole.

(For 8" (200 mm) spools, a K468 spindle adapter must first be slipped onto spindle.)

(For 13-14 lb. (6 Kg) Innershield coils, a K435 Coil Adapter must be used).

- 1) Depress the Release Bar on the Retaining Collar and remove it from the spindle. **NOTE:** Earlier spindles used a threaded collar.
- 2) Place the spool on the spindle making certain the spindle brake pin enters one of the holes in the back side of the spool. Be certain the wire comes off the reel in a direction so as to de-reel from the bottom of the coil.
- 3) Re-install the Retaining Collar. Make sure that the Release Bar "pops up" and that the collar retainers fully engage the retaining groove on the spindle.

LOADING A 50-60 LB. (22.7-27.2 KG.) COIL USING K1504-1 COIL REEL:

(For 50-60 lb Readi-Reels a K438 Readi Reel Adapter must be used.)

The Spindle must be located in the **UPPER** mounting hole.

1. With the K1504-1 Coil Reel mounted on to the 2" (51 mm) spindle (or with reel laying flat on the floor) loosen the spinner nut and remove the reel cover.
2. Before cutting the tie wires, place the coil of electrode on the reel so it unwinds from the bottom as the reel rotates.
3. Tighten the spinner nut against the reel cover much as possible by hand using the reel cover spokes for leverage. **DO NOT** hammer on the spinner nut arms.
4. Cut and remove only the tie wire holding the free end of the coil. Hook the free end around the rim of the reel cover and secure it by wrapping it around. Cut and remove the remaining tie wires.

FEEDING ELECTRODE AND BRAKE ADJUSTMENT

1. Turn the Readi-Reel or spool until the free end of the electrode is accessible.
2. While tightly holding the electrode, cut off the bent end. Straighten the first six inches. Cut off the first inch. (If the electrode is not properly straightened, it may not feed or may not go into the outgoing guide tube, causing a "birdnest.")
3. Insert the free end through the incoming guide tube.
4. Press the gun trigger or "cold inch" (if used) and push the electrode into the drive roll.

WARNING

USE THE "COLD" TRIGGER SWITCH POSITION, OR "COLD INCH" OPTION WHEN LOADING. WHEN INCHING WITH A "HOT" GUN TRIGGER, THE ELECTRODE AND DRIVE MECHANISM ARE ALWAYS "HOT" TO WORK AND GROUND AND COULD REMAIN "HOT" SEVERAL SECONDS AFTER THE GUN TRIGGER IS RELEASED.

5. Inch the electrode through the gun.
6. Adjust the brake tension with the thumbscrew on the spindle hub, until the reel turns freely but with little or no overrun when wire feeding is stopped. Do not overtighten.

LOADING 50 AND 60 LB. COILS ON 1" SPINDLE (K299 or K303 Wire Reel Stand)

ADJUSTABLE WIRE REEL BRAKE

The mount for standard 50 and 60 pound electrode coils includes a two position brake assembly. Generally the brake should be at the inner position (nearest to the wire reel shaft) for wire feed speeds below 400 in/min. It should be at the outer position for the faster wire speeds often used when feeding small diameter electrode.

To adjust the brake position, remove the wire reel. Pull the cotter pin that holds the brake shoe to the arm, move the shoe and replace the cotter pin. Do not bend the cotter pin - it is held in place by a friction fit.

LOADING A 50 OR 60 LB. COIL

1. To remove the wire reel from its shaft, grasp the spring loaded knob and pull it out. This straightens the knob so that it seats into the shaft when released. Remove the reel.
 2. Lay the reel flat on the floor, loosen the spinner nut and remove the cover plate.
 3. Before cutting the tie wires, place the coil of electrode on the reel so that it unwinds as the reel rotates clockwise.
- a) Be sure the coil is placed so that the spring loaded arms will not interfere with the later removal of the coil tie wires. See Figure B.8.

FIGURE B.8 – LOADING A 50 OR 60 LB. COIL

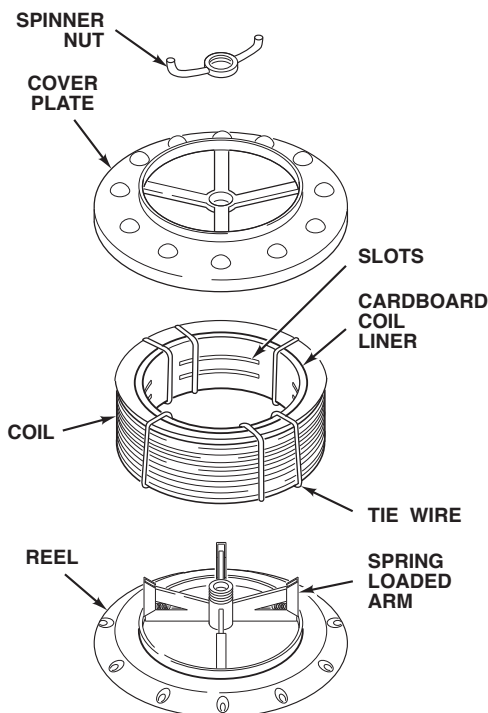

- b) When loading 0.030, 0.035 and 0.045" electrode, be certain the coil is placed on the reel so that the spring loaded arms are at the center of the slots in the cardboard coil liner. This provides the positive compression of the coil sides needed for trouble free wire feeding. See Figure B.8.
- c) Put the cover plate on the reel so that the four arms of the cover straddle and are in line with the spring loaded arm of the reel.
4. Tighten the cover as much as possible by hand. **DO NOT** hammer on the spinner nut arms.
5. Cut and remove only the tie wire holding the free end of the coil. Insert the free end into one of the holes in the cover and secure it by bending it back. Cut and remove the remaining tie wires.

CAUTION

Always be sure the free end of the coil is securely held while the tie wires are being cut and until the wire is feeding through the drive rolls. Failure to do this will result in "backlashing" of the coil, which may tangle the wire. A tangled coil will not feed; therefore it must either be untangled or discarded.

6. Replace the reel on the wire feeder. Grasp the shaft knob, pull it out and swing it across the reel hub, locking the reel in place.
7. The mount for standard 50 and 60 pound electrode coils includes a two-position brake assembly. Generally the brake should be at the inner position (nearest to the wire reel shaft) for wire feed speeds below 400 in/min. It should be at the outer position for the faster wire speeds often used when feeding small diameter electrode.

To adjust the brake position, remove the wire reel. Pull the cotter pin that holds the brake shoe to the arm, move the shoe and replace the cotter pin. Do not bend the cotter pin - it is held in place by a friction fit.

LN-9 GMA and LN-9F GMA Wire Feeder



OPERATION

FEEDING ELECTRODE AND BRAKE ADJUSTMENT

1. Turn the reel until the free end of the electrode is accessible.
2. While tightly holding the electrode, cut off the bent end. Straighten the first 6 inches.
3. Cut off the first inch. Insert the free end through the incoming guide tube.
4. Insert the free end through the incoming guide tube.
5. Press the gun trigger or "cold inch" (if used) and push the electrode into the drive roll. (If the electrode is not properly straightened, it may not feed or may not enter the outgoing guide tube, causing a "birdnest.")
6. Inch the electrode through the gun.

WARNING

USE THE "COLD" TRIGGER SWITCH POSITION, OR "COLD INCH" OPTION WHEN LOADING. WHEN INCHING WITH A "HOT" GUN TRIGGER, THE ELECTRODE AND WIRE FEEDING SYSTEM ARE ALWAYS "HOT" TO WORK AND GROUND AND COULD REMAIN "HOT" SEVERAL SECONDS AFTER THE GUN TRIGGER IS RELEASED.

LOADING AND FEEDING 13-14 LB. INNERSHIELD COILS (K378 REEL MOUNTING STAND)

The K378 small mounting stand for the 14 pound Innershield coil does not have an adjustable brake. It has a fixed drag built into the reel spindle.

To load a 14 pound coil:

1. Remove the snap-on lid from the plastic canister.
2. Remove the center clamping nut and the cover plate from the wire reel.
3. Unpack the 14-pound coil of wire. Be sure not to bend the side tangs of the coil liner. Straighten any tangs that may have been bent.
4. Remove the start end of the coil from its holding slot in the coil liner, cut off the bent end, straighten the first six inches, and cut off the first inch. (If the electrode is not properly straightened, it may not feed or may not go into the outgoing tube, causing a "birdnest.") Thread it through the canister wire feed liner until about four inches of electrode are exposed.
5. Place the coil onto the disc support.
6. Replace the front reel cover and center clamping nut, keep the reel from turning and tighten the clamping nut securely.
7. Thread the exposed end of the electrode into the wire feeder until it touches the drive rolls. Actuate the gun trigger, and feed the electrode through the system.

IDLE ROLL PRESSURE SETTING

The idle roll pressure is set at the factory backed out two turns from full pressure for 2-roll feeders, three turns from full pressure for 4-roll feeders. This is an approximate setting. For small wire sizes and aluminum wire, the optimum idle roll pressure varies with type of wire, surface condition, lubrication and hardness. The optimum idle roll setting can be determined as follows:

2-ROLL WIRE FEEDERS

1. Press the end of the gun against a solid object that is electrically isolated from the welder output and press the gun trigger for several seconds.
2. If the wire "birdnests," jams or breaks at the drive roll, the idle roll pressure is too great. Back the pressure setting out 1/2 turn, run new wire through the gun, and repeat step 1. See Figure B.9.
3. If the only result is drive roll slippage, loosen the gun cable clamping screw in the gearbox conductor block and pull the gun cable forward about six inches. There should be a slight waviness in the exposed wire. If there is no waviness, the pressure is too low. Increase the pressure setting 1/4 turn, lock the gun cable in place and repeat steps 1 and 2.

4-ROLL WIRE FEEDERS

1. Release the incoming idle roll and perform the pressure setting procedure for two-roll wire feeders to set outgoing idle roll pressure.
2. After the outgoing pressure is set, determine how many turns away from full pressure the setting is.
3. Set both idle roll tensions to this setting. Engage both idle rolls before welding. For most applications, best wire feeding will occur when both idle roll pressures are set the same.

FIGURE B.9 – IDLE ROLL PRESSURE SETTING FOR TWO-ROLL FEEDERS

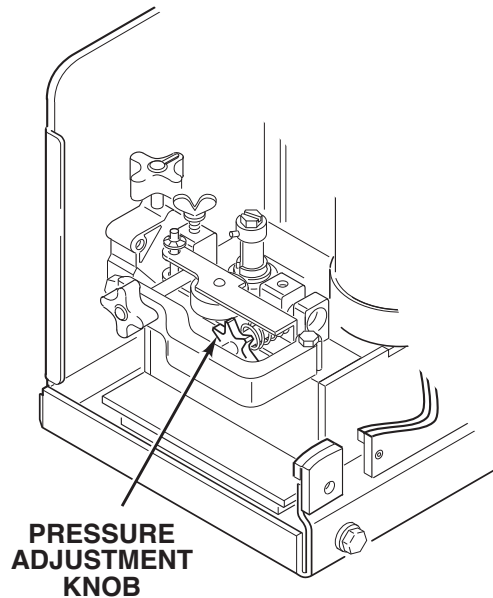

MAKING A TEST WELD AND ADJUSTING LN-9 GMA RESPONSE AND STARTING CHARACTERISTICS

ADJUST THE POWER SOURCE

DC-250, DC-400, or DC-600

1. Connect electrode lead to terminal of desired polarity.
2. Set toggle switch to same polarity as the electrode cable connection.
3. Set toggle switch to "Output Control Remote."
4. Set mode switch to the desired position for the process to be used.

CV-400, CV-500-I

1. Connect electrode lead to terminal of desired polarity.
2. Connect #21 control lead to the work polarity terminal (+21 or -21), at the terminal strip, matching the same polarity as the work cable connection.
3. Set toggle switch to "Output Control Remote."

R3S-400, R3S-600, R3S-800

1. Connect electrode lead to terminal of desired polarity.
2. Set toggle switch to same polarity as the electrode cable connection.
3. Set the toggle switch to "Remote."
4. Install voltage triangle to a position as close as possible to desired arc voltage.

NOTE: Since the LN-9 GMA cannot control the fixed OCV of R3S power sources, starting difficulties may be experienced when striking the arc of processes which use a low voltage or a narrow voltage range. The following steps should remedy this difficulty:

1. The electrode stickout when starting should be as close to procedural length as possible, and the tip of the electrode should be clean and held nearly touching the work.
2. Install the R3S voltage triangle to the position higher than the desired arc voltage, provided it does not result in out of range shutdown of the LN-9 GMA while welding.

PULSE POWER 500, DC650 PRO, V300

Refer to each machine Instruction Manual. The LN-9 GMA requires the K442-1 Pulse Power Filter Kit. (See the **Accessories** section of this manual.)

ADJUST THE LN-9 GMA CONTROLS

1. Set the "Electrode Polarity" switch to same polarity as the electrode lead.
2. Check that "Feed Direction" is set to forward.
3. Set the "Trigger Interlock" switch as desired.
4. Set the "Meter Reading" switch to "Wire Speed" and adjust the "Wire Speed" rheostat so the meter reads the desired wire feed speed.
5. Set the "Meter Reading" switch to "Volts" and adjust the "Volts" rheostat so the meter reads the desired arc voltage. **IMPORTANT:** Make certain this setting is within the voltage output range of the power source setting.
6. Load the LN-9 GMA with electrode.

VOLTAGE CONTROL RESPONSE

The LN-9 GMA is provided with selectable voltage control response. Proper setting depends on the power source and process being used. Refer to the appropriate power source connection diagram for the proper connection of the jumpers located on the LN-9 GMA Voltage Board.

To change the voltage control response:

- Turn OFF the control power to the LN-9 GMA at the power source.
- Remove the screws holding the control section cover in place and swing open.
- Position the jumper plugs on the Voltage Board according to the appropriate power source connection diagram.
- Reassemble.

STARTING CHARACTERISTICS

SELECT ACCELERATION

The LN-9 GMA models can provide optimum starting for different processes. The wire feeder is designed to start with two different speeds of controlled acceleration. As shipped, it is connected for fast acceleration, which is the best for most open arc procedures. However, the slower acceleration may be more desirable for long stickout applications and most submerged arc procedures. If the electrode being used does not give satisfactory starting because of "stubbing" or "blasting off," slower acceleration can be obtained by modifying the LN-9 GMA models as follows:

- Turn OFF the control power to the LN-9 GMA at the power source.
- Remove the screws holding the control section cover in place and swing it open.
- On machines having an L7253 Control PC board, move the jumper plug on the PM Control PC board from pin "F" to pin "S."

On machines having an L10068 Control PC board, set the DIP switch on the PM Control PC board to the "S" position.
- Reassemble.

START VOLTAGE TRIM

The start voltage is the voltage provided by the welding power source before establishing the welding arc. This start voltage setting is a function of the open circuit voltage characteristic of the power source, the SET value of the weld voltage, and the start voltage trimmer (R41) setting on the LN-9 Voltage PC Board. As set at the factory, the start voltage trim level is typically about 20% higher than the LN-9 GMA SET level. This generally gives good starting for steel cored and MIG processes using CO₂ or Argon/CO₂ blended shielding gas. If you are using "hotter" gases (such as Argon/Oxygen blends) and other processes (such as stainless steel MIG), arc flaring may occur at start, which requires lowering the start voltage trim as follows:

- Turn off the control power to the LN-9 GMA at the power source.
- Remove the screws holding the control section cover in place and swing it open.
- On the voltage board, locate trimmer R41 (below R40 next to the 1/8 amp fuse) and labeled START.
- The slot on the START trimmer is marked with a red seal for factory setting. To decrease the factory setting, turn the slot CCW (opposite to the labeled arrow direction).

NOTE: If the start trim is set too low, stubbing may occur at start, requiring increasing the START trimmer by turning the slot CW (in the direction of the labeled arrow).

- Re-assemble.

RUN-IN FEATURE

On new machines (above code 10350) a "Run-in" trimmer, labeled "RUN-IN," is provided on the new L10068-1 Control PC board.

This trimmer can be used to set the run-in wire feed speed as a percentage of the weld speed. When the trimmer is turned fully counterclockwise, the run-in speed is about 5% of the weld speed. When the trimmer is turned fully clockwise, the run-in speed is equal to the weld speed. To increase the run-in speed, turn the trimmer clockwise; and to decrease the run-in speed, turn the trimmer counterclockwise.

The factory setting of the run-in trimmer is about 20%. The trimmer should be set lower if arc starting tends to stub or blast, and it should be set higher if the arc tends to flare up. When the Actual button is pressed, the actual speed setting can be viewed on the digital speed meter for two seconds after closing the trigger or the cold inch switch.

OPERATION

MAKING A WELD

1. Inch the electrode through the gun and cable and then cut the electrode within approximately 3/8" of the end of the contact tip for solid wire and within approximately 3/4" of the extension guide for cored wire.
2. Connect the work cable to the metal to be welded. The work cable must make good electrical contact to the work. The work must also be grounded as stated in the Safety section at the beginning of this manual.
3. Be sure the welding power source and the shielding gas supply are turned on.
4. Position the electrode over the joint. The end of the electrode should be slightly over the joint.
5. Lower the welding helmet, close the gun trigger and begin welding. Hold the gun so that the contact tip to weld distance gives the correct electrical stickout as required for the procedure being used.
6. To stop welding, release the gun trigger and then pull the gun away from the work after the arc goes out.

PROCEDURE AT END OF COIL

When the wire on the reel is used up, follow this procedure for removing the old wire from the conductor cable and loading a new reel.

1. Cut the end of the electrode off at the gun end. Do not break it off by hand since this puts a slight bend in the wire and makes it difficult or impossible to pull it back through the nozzle.
2. Uncouple the gun conductor cable from the wire drive unit.
3. Lay the cable out straight.
4. Using pliers to grip the wire, pull it out of the cable from the connector end. Do not pull it from the gun end.
5. Put the conductor cable back on the wire drive unit after the electrode has been removed.
6. Load a new reel of wire and feed it through the cable as described earlier in this section.

SECURITY OF WELD PROCEDURE SETTINGS

There are two ways to prevent or limit unauthorized readjustment of the LN-9 GMA voltage and wire feed speed controls.

1. Once the procedure is set, the security panel of the LN-9 GMA can be locked to prevent access to the control knobs.
2. The control range of the procedure control knobs can be limited to either about 3% or about 15% of the full range control by installing a knob rotation stop screw to either or both of the control knobs. This stop screw is installed in the following manner:
 - a) Turn off the input power to the LN-9 GMA unit.
 - b) Loosen the knob set screw and remove the control knob and the felt seal located behind the knob.
 - c) Remove the control potentiometer locknut and fiber spacer, then open the control panel and remove the potentiometer from the panel.
 - d) Install a 1/2" long, pan or round head, #4 sheet metal screw into the 0.10" dia. hole located .40" from the center of the potentiometer hole so that the head is on the back side of the panel (inside the control box).
 - e) Remount the control potentiometer with the fiber spacer under the locknut, then close and secure the control panel.
 - f) Replace the felt seal around the fiber spacer so that the #4 screw protrudes between the fiber spacer and the felt seal.
 - g) Turn on the input power to the LN-9 GMA unit and set the desired procedure by rotating the potentiometer shaft.
 - h) Carefully replace the control knob so that the #4 screw inserts into the center of the shorter length channel on the back of the knob for about 3% of the total range of control, or the center of the longer length channel for about 15% of the total range of control.
 - i) With finger pressure on the knob against the felt seal, carefully retighten the knob set screw.

NOTE: Steps g) through i) will have to be repeated if you want to change the set procedure to a value outside the selected 3% or 15% control range limit.

ACCESSORIES

AUXILIARY EQUIPMENT CONTACTS

The power for 115 volt AC auxiliary equipment can be obtained from the terminals inside the LN-9 GMA control box. The contacts are "hot" whenever the trigger is pressed or the unit is welding. The current draw of this circuit must not exceed 1/4 ampere.

WARNING

TURN THE INPUT POWER TO THE POWER SOURCE OFF AT THE DISCONNECT SWITCH BEFORE PERFORMING THE FOLLOWING WORK.

LN-9 GMA MODEL:

Install 1/4" quick connect terminals to the leads from the auxiliary equipment. Route the leads to the terminals marked #32A and #7 which come through the rectangular hole in the control section sheet metal near the wire feed motor.

LN-9F GMA 2-ROLL AND 4-ROLL MODELS:

Install terminals for #6 screws to the leads from the auxiliary equipment. Route the leads to the terminals #32A and #7 on the terminal strip on the inside bottom of the control box.

NOTES:

1. The K418 and K419 burnback timer does not delay the opening of the auxiliary equipment contacts. If you want to continue power to auxiliary equipment during the burnback time, this can be accomplished only if you are using an R3S, DC-400 or DC-600 power source. Connect the 115 volt AC auxiliary equipment leads to #4 and #31 on the power source terminal strip. The auxiliary equipment power requirements should not exceed 15 watts.

This alternate connection cannot be used with the DC-250 or CV-400, 500-I Power Sources.

2. If the LN-9 GMA gas solenoid valve is not required, the gas solenoid terminals (#32A and #7A) may be used in conjunction with the K418 GMA Timer Kit to obtain pre-weld and/or post-weld timing functions for 115V AC auxiliary equipment. However, the gas solenoid must be disconnected and the auxiliary equipment current draw must not exceed 1/4 ampere.

OPTIONAL EQUIPMENT AND ACCESSORIES

POWER INPUT CABLE ASSEMBLIES (K196, K595, K596)

Required to connect wire feeder to power source. Includes multiconductor control cable and the proper size electrode cable for the welding current to be used. Specify length and maximum welding current.

- K196 Input Cable Assemblies - For power sources with terminal strip wire feeder connections and stud output terminals.
- K595 Input Cable Assemblies - For power sources with MS-type (Amphenol) wire feeder receptacle and stud output terminals.
- K596 Input Cable Assemblies - For power sources with MS-type (Amphenol) wire feeder receptacle and Twist-Mate™ output connectors.

WIRE REEL STANDS AND MOUNTINGS

50-60 LB. WIRE REEL MOUNTING STAND (K303)

The assembly includes a framework to which is attached the 50-60 lb. wire reel, a mounting spindle, a dust shield, a lift bail, and a cable clamp for fastening the input cable assembly. It is easily mounted to the basic wire feed unit by three bolts. The reel mounting spindle is the pull knob type with a built-in brake.

The brake pad is adjustable for proper braking at low or high wire feed speeds.

50-60 LB. READI-REEL® MOUNTING STAND (K445)

The assembly includes a framework to which is attached a 2" O.D. spindle with adjustable brake and 50-60 lb. Readi-Reel Adapter. Includes a lift bail and cable clamp for fastening the input cable assembly, and easily mounts to the LN-9 GMA feeder. Does not include dust shield.

Can also be used for up to 60 lb. spools with 2" I.D.

ACCESSORIES

ATTACHING THE WIRE REEL STANDS

The mounting hardware for mounting the stands is included with the LN-9 GMA. Screws and washers are inserted in their respective mounting holes. To connect:

1. Remove the three 3/8 in. hex head bolts from the back of the wire feed unit.
2. Place the wire reel mounting stand mounting bracket in position against the back of the wire feed unit.
3. Replace and tighten the hex head bolts. The long screw and plain washer go into the top hole.

WIRE REEL DOOR KIT

Mounts to K303 or to K445 equipped with an S14543 dust shield housing kit, to completely enclose wire reels against extremely dusty and dirty environments. Includes a hinged door and sliding bottom seal. Install the door according to instructions included with the kit.

SPINDLE FOR READI-REELS AND 2" I.D. SPOOLS (K162-H*)

(60 Lb. Maximum Capacity)

The 2" O.D. spindle kit is for use with the K303. The shaft for the standard 50-60 pound wire coils is removed from the mounting framework, and the K162H is installed in its place. Includes an easily adjustable friction brake for control of overrun.

When used with Readi-Reels, a Readi-Reel Adapter is required.

When used with 8" O.D. spools, a K468 Spindle Adapter is available.

14 Lb. Innershield coils can be mounted to the spindle using the K435 Adapter.

* Replaces the K162 30 Lb. Spindle Kit.

Install the spindle according to instructions included with the kit:

K162 - 30lb (13.6 kg) – M14573 Mounting instructions
K162H - 60 lb (27.2 kg) – M15241 Mounting instructions

CAUTION

DO NOT USE COILS OR SPOOLS HEAVIER THAN 30 LBS. ON THE ORIGINAL K162 SPINDLE.

READI-REEL ADAPTERS

K363-P Adapts Lincoln Readi-Reel coils of electrode (30 lb. and 22 lb.) to a 2" spindle. One-piece construction. Made from a durable molded plastic. Designed for easy loading; adapter remains on spindle for quick changeover. Included with K377 small mounting stand.

K438 Adapts 50-60 lb. Lincoln Readi-Reel coils to a K162-H spindle, or similar 2 inch spindle suitable for 60 lb. spools. Two-piece construction made from a durable flame retardant molded plastic. Designed for minimum loading downtime, the coils easily load with inside adapter half on spindle. Four twist latches lock adapter halves together. Included with K445 50-60 lb. Readi-Reel stand.

60 LB. (27.2 KG) COIL ADAPTER (K1504-1)

Permits 50-60 lb. (22.7-27.2 Kg) coils to be mounted to a 2" (51mm) spindle.

SMALL MOUNTING STAND FOR READI-REEL COILS OR 2" I.D. SPOOLS (K377)

(30 Lb. Maximum Capacity)

This assembly includes a small frame to which is attached a wire reel spindle similar to the K162 spindle. The unit is supplied with the K363 Readi-Reel Adapter for use with the Lincoln 22-30 lb. Readi-Reel Electrode Coils. Without the adapter the unit is capable of handling up to 30 lb. spools with a 2" I.D., a 12" max. O.D., and a 4" width. For spools with an 8" O.D., a K468 Spindle Adapter is available.

14 lb. Innershield coils can be mounted to the spindle using the K435 Adapter. The spindle has an easily adjustable braking system.

SMALL MOUNTING STAND FOR 13-14 LB. INNER-SHIELD COILS (K378)

This assembly includes the same smaller frame as used in the K377 and a fully enclosed canister system for de-reeling of the 14 pound coil. This system has a fixed brake for the 14 pound coil.

50-60 LB. WIRE REEL ASSEMBLY FOR CUSTOMER MOUNTING (K299)

This assembly is available only when ordering either the LN-9F GMA 2-Roll or 4-Roll model. It includes a 50-60 lb. wire reel, spindle shaft, adjustable brake, insulation and mounting hardware.

Install the assembly according to instructions included with it.

ACCESSORIES

UNIVERSAL WIRE REEL STAND (K1524-1)

Includes a 2" (51mm) O.D. Spindle with adjustable brake and two locations for mounting the spindle to allow for the mounting of 50 - 60lb, 10 - 30 lb, 13 - 14lb, and 8" O.D. coils with proper spindle adapters. (See OPERATION section) Capable of being mounted on the top of a suitable power source or surface without the need for any other mounting kit. Optional features available for this stand include:

- K1555-1 insulated lift bale
- K1556-1 caster kit
- K1557-1 swivel platform.

K1551-1 Insulated Lift Bale: Provides a bolt on lift bale with an electrically insulated lift hook.

K1556-1 Caster Kit: Comes with 4 light duty 2" O.D. casters which mount in place of the rubber feet on the wire stand. Use in light duty applications where portability is required. Can be used in combination with the K1557-1 swivel platform.

K1557-1 Swivel Platform: Allows for the mounting of the wire feeder reel stand assembly on top of a suitable power source if the need for the wire feeder reel stand assembly to swivel is desired. Also has mounting holes in the base feet for mounting to any surface that it can be fastened to. Comes with a rotating tool tray to hold gun tips, guide tubes, drive rolls, etc. Will work in combination with the K1556-1 caster kit.

ACCESSORIES

GUN AND CABLE ASSEMBLIES

A variety of standard Lincoln and Magnum gun and cable assemblies are available for the LN-9 GMA in

10 ft., 12 ft. and 15 ft. cable lengths. Choose the gun and cable assembly to suit the LN-9 GMA welding application and wire size. See Table C-1.

TABLE C.1 – LN-9 GMA GUN AND CABLE ASSEMBLIES

Process	Model	Electrode	60% Duty Rating
Gas Metal Arc (GMA)	K426	.035-.052" (0.9-1.3 mm) solid .045- $\frac{5}{64}$ " (1.1-2.0 mm) cored	350 amps 350 amps
	K427	.045- $\frac{1}{16}$ " (1.1-1.6 mm) solid $\frac{1}{16}$ - $\frac{5}{64}$ " (1.6-2.0 mm) cored	500 amps 500 amps
	Magnum K470 ⁽¹⁾	.035- $\frac{1}{16}$ " (0.9-1.6 mm) solid .035- $\frac{5}{64}$ " (0.9-2.0 mm) cored	300 amps 300 amps
	Magnum K471 ⁽¹⁾	.035- $\frac{1}{16}$ " (0.9-1.6 mm) solid .035- $\frac{5}{64}$ " (0.9-2.0 mm) cored	400 amps 400 amps
	Magnum K478 ⁽²⁾	.035- $\frac{1}{16}$ " (0.9-1.6 mm) solid .035- $\frac{5}{64}$ " (0.9-2.0 mm) cored	300 amps 300 amps
	Magnum K479 ⁽²⁾	.035- $\frac{1}{16}$ " (0.9-1.6 mm) solid 0.35- $\frac{5}{64}$ " (0.9-2.0 mm) cored	400 amps 400 amps
Innershield®	K126	.068- $\frac{5}{64}$ " (1.7-2.0 mm) Innershield	350 amps
	K115	$\frac{5}{64}$ " (2.0 mm) Innershield	450 amps
	K206 ⁽³⁾	.068- $\frac{5}{64}$ " (1.7-2.0 mm) Innershield	350 amps
	K289 ⁽³⁾	$\frac{5}{64}$ " (2.0 mm) Innershield	500 amps
	K309 ⁽³⁾	.068- $\frac{5}{64}$ " (1.7-2.0 mm) Innershield	250 amps
Submerged Arc	K112	$\frac{1}{16}$ " (1.6 mm) Solid	500 amps

⁽¹⁾ K466-1 connector kit required.

⁽²⁾ K489 Fast-Mate™ Adapter required.

⁽³⁾ Linconditioner™ guns are recommended for locations where smoke accumulation is a problem and conventional exhaust systems are ineffective. The available smoke removal type Innershield guns and vacuum units can be used in these locations. Instructions are shipped with the equipment.

WIRE FEEDER ACCESSORIES

BURNBACK TIMER KIT (K419)

Provides a precise control of the electrode burnback at the end of the weld. Prevents crater sticking and provides proper stickout for starting the next weld. Recommended especially when welding with small (0.023-1/16") diameter wire at high wire feed speeds. Also includes a cold inch switch. (Can be installed only in GMA models.)

Install the kit according to the M15060 instructions included with the kit.

LN-9 GMA and LN-9F GMA Wire Feeder



ACCESSORIES

GMA TIMER KIT (K418)

Provides the following functions:

1. **Preflow Control** - Provides flow of shielding gas to the work before the arc is established. The solenoid valve is energized immediately when the gun trigger is closed but the time delay before the wire feeder is energized is adjustable from 0 to 1.5 seconds.
2. **Postflow Control** - Provides flow of shielding gas to the work after welding is stopped. Delay of the shut off of the solenoid valve after the gun trigger is released is adjustable from 0.5 to 4.5 seconds.
3. **Burnback Control** - Provides a precise time delay that allows the wire to be burned off at the end of the weld. The delay is adjustable for optimum burnback depending on wire size, processes, procedure, etc.
4. **Purge - Cold Inch Switch** - One momentary position energizes the gas solenoid valve but not the wire feeder or power source. The other momentary position energizes the wire feeder but not the power source or solenoid valve. For GMA models only.

Install the kit according to the M15059 instructions included with the kit.

DUAL PROCESS KIT (K317) - For Wire Feeders Using Same Polarity

This kit permits the connection of two wire feeders to a single power source. Both feeders must weld with the same electrode polarity. When the trigger of the desired wire feeder is pressed, the power source output control leads (#75, #76 and #77) will be connected to that feeder, and the procedure as set on its controls will be provided. The other connected wire feeder will not be feeding wire, but its electrode circuit will be electrically hot. The kit mounts at the power source and is connected to the power source terminal strip with the supplied leads. Standard K196 input cable assemblies are used to connect each wire feeder to the dual process control circuit while the electrode lead connects to the power source.

Install the kit according to instructions included.

DUAL PROCESS KIT (K318) - With Electrode Polarity Change Capability

Functions essentially the same as the K317 except that the kit includes two contactors to provide different polarities on the two wire feeders. When connected in this manner and one trigger is pressed, the other elec-

trode will be "cold" to ground but "hot" to the other electrode. This kit can also be connected to provide the same polarities on each feeder, but the electrode circuit of the one not being used will be cold to work and to the other electrode.

Install the kit according to instructions included.

NOTE: The K317 and K318 Dual Process Kits also include mode change capability, but only when using the DC-600 power source. This feature permits one feeder to weld in CV Innershield mode and the other feeder to weld in CV Submerged Arc mode, as well as both in the same mode.

When using the Pulse Power 500 power source, the K317 or K318 Dual Process Kits can be used only if the procedures are close enough to use the same mode setting. The K317 or K318 cannot switch modes on the Pulse Power 500. An LN-9 GMA may not be used with an LN-7 or LN-8, although two LN-9 GMAs may be used together.

DUAL PROCEDURE KIT (K319)

With the use of this kit, one of two different settings of wire feed speed and voltage can be selected by a toggle switch mounted on the gun handle. The kit consists of a control panel which mounts over the standard LN-9 GMA control rheostats. This control panel has four rheostats, a transfer relay and a polarized connector. During installation, the standard security door is mounted over the new panel and functions in the same manner. All electrical connections are with plugs to speed and simplify the assembly. A 15-foot control cable with a polarized connector on one end for plugging into the new control panel is provided. On the other end of the control cable is a small selector toggle switch and a mounting bracket.

A K302 Extension Control Cable is required when using the K319 with any LN-9F model.

Install the kit according to instructions included.

PULSE POWER FILTER CONVERSION KIT (K442-1)

Required for any LN-9 GMA to be used with a Pulse Power 500, DC650 Pro, or Invertec V300 power source. Includes a Filter Board and connection harness, easily installed in the control section and plugged into the Voltage Board. The plug must be disconnected for use with other standard power sources.

Install the kit according to instructions included.

LN-9 GMA and LN-9F GMA Wire Feeder



ACCESSORIES

SWIVEL PLATFORM (K178-1)

For all LN-9 GMA wire reel stand combinations. For mounting wire feeder-wire reel stand assembly on top of suitable Lincoln Idealarc power sources. Recommended input cable assembly length is 10 feet (3m) when using the K178-1.

Bolt the platform to the lift bail according to instructions supplied with the platform (M16260).

UNDERCARRIAGE (K163)

For all LN-9 GMA wire reel stand combinations. Includes mounting frame, front casters, 10" (254 mm) O.D. rear wheels, and handle. Use when portability is required. Casters mount at the front and the wheels mount at the rear. Handle bolts to the front, which allows the LN-9 GMA to be tilted back and wheeled like a two-wheel truck.

CONTINUOUS FLUX FEED TANK (K320)

The K320 is available to permit the LN-9 GMA to be used for submerged arc welding using the K112 submerged arc gun and cable. Requires a supply of compressed air at 60 to 120 psi with a flow of 1.5 cubic feet per minute.

The kit is a complete continuous flux feeding system including air filter, pressure regulator, gage, tank and 18 foot flux hose. It also includes a funnel for filling the tank, plus the lift bail assembly required to mount the tank and wire feeder to a K163 undercarriage. The tank can also be used as a free standing assembly.

Install the tank according to instructions included with the K320 kit.

K320 FLUX TANK LOADING

Either turn off the incoming air line or remove the quick disconnect if one has been installed. Slightly loosen the tank cap and let the air in the tank escape through the holes in the side of the cap. After pressure has been released, remove the cap from the tank. Using the funnel provided, put 100 pounds of flux into the tank. It is very important that only new or properly reclaimed flux be put in the tank. Coarse particles and/or magnetic particles will stop the flux feeding process. New Lincoln flux is properly screened at the factory. All reclaimed flux must be separately screened through a vibrated screen having 0.065 - 0.075 openings and be put through a magnetic separator. The K310 vibrated Flux Screen and a K58 Magnetic Separator are available for this purpose. The screen in the funnel supplied with the tank has much larger openings, and its only purpose is to keep paper and slag out of the tank. Screw the tank cap back on and tighten it hand tight. Reconnect the incoming air line to the tank.

There will always be a small amount of air and possible drops of water coming out of the end of the tube coiled under the tank. This is an automatic disposal system in case the plant air has water and dirt in it.

K310 FLUX SCREEN

This unit is designed to fit the top of either the standard fill funnel of a continuous flux feed system or a K58 magnetic separator. The unit has a steel screen with 0.065 to 0.075 openings and an air vibrator attached to the frame. The vibrator can be used with air line pressure ranging from 20 psi to 100 psi.

For ease of handling, you should connect the incoming air line to the 1/8" pipe elbow with the aid of a fast disconnect type air coupling.

It is very important that reclaimed flux to be used in the continuous flux feeding system be passed through the K310 screen or its equivalent.

K58 MAGNETIC SEPARATOR

The K58 is a permanent magnet type separator designed to fit the top of the standard fill funnel of the continuous flux feed system.

The purpose of the separator is to remove magnetic materials such as mill scale and any other extraneous magnetic materials which may have been recovered along with the flux to be processed.

It is important to remove these magnetic particles from the flux which is to be reused in the continuous flux feeding system. If the magnetic material is not removed, it will gather around the nozzle of the gun and impede or shut off the flux flow when making relatively long welds or when welding continuously. The magnetic particles can also cause porosity in the weld.

Fit the magnetic separator into the funnel or hopper. Pour the flux to be reclaimed into the top pan of the separator. The separator is designed so that the flux flows around three permanent magnets. The magnets remove all magnetic particles. When the magnets become covered with their full load, they automatically stop the flux flow. When the flux flow stops, remove the separator from the funnel or hopper. Turn it over and open the panel that covers the magnets. Remove the magnetic particles by brushing or by using an air blast.

WARNING

WHEN USING COMPRESSED AIR BE CAREFUL TO PROTECT YOURSELF AND OTHERS IN THE AREA FROM FLYING PARTICLES.

NOTE: The magnetic separator is used with all Lincoln mild steel fluxes - 700 Series, 800 Series and 900 Series. Do not use the magnetic separator with any stainless steel, alloy, or hardsurfacing flux except H-535. The magnetic separator removes some of the alloying elements from these fluxes, thus changing their characteristics.

TABLE C.2 – DRIVE ROLL AND GUIDE TUBE KITS

Wire Size	Kit	
	2-Roll	4-Roll
<u>Solid Steel Electrode</u>		
0.023" - 0.025" (0.6 mm)	KP653 - 025S	KP655 - 025S
0.030" (0.8 mm)	KP653 - 030S	KP655 - 030S
0.035" (0.9 - 1.0 mm)	KP653 - 035S	KP655 - 035S
0.045" and 0.052" (1.2 - 1.4 mm)	KP653 - 052S	KP655 - 052S
0.062" (1.4 - 1.6 mm)	KP653 - 1/16	KP655 - 1/16
0.068" (1.7 mm)	_____	KP655 - 3/32
5/64" (2.0 mm)	_____	KP655 - 3/32
3/32" (2.4 mm)	_____	KP655 - 3/32
<u>Cored Electrode</u>		
0.035" (0.9 - 1.0 mm)	KP653 - 035C	KP655 - 035C
0.045 and 0.052" (1.2 - 1.4 mm)	KP653 - 052C	KP655 - 052C
0.062" (1.4 - 1.6 mm)	KP653 - 1/16	KP655 - 1/16
0.068" (1.7 mm)	KP653 - 3/32	KP655 - 3/32
5/64" (2.0 mm)	KP653 - 3/32	KP655 - 3/32
3/32" (2.4 mm)	KP653 - 3/32	KP655 - 3/32
<u>Aluminum Electrode</u>		
0.035" (0.9 - 1.0 mm)	KP654 - 035A	KP656 - 035A
3/64" (1.2 mm)	KP654 - 3/64A	KP656 - 3/64A
1/16" (1.6 mm)	KP654 - 1/16A	KP656 - 1/16A

SAFETY PRECAUTIONS

WARNING



ELECTRIC SHOCK can kill.

- Only qualified personnel should perform this maintenance.
 - Turn the input supply power OFF at the disconnect switch or fuse box before working on this equipment.
- Do not touch electrically hot parts.

ROUTINE MAINTENANCE

DRIVE ROLLS AND GUIDE TUBES

After feeding any coil of wire, inspect the drive roll section. Clean it as necessary. Do not use a solvent for cleaning the idle rolls(s) because it may wash the lubricant out of the bearing. The drive roll(s) and guide tubes are stamped with the wire sizes they will feed. If you use a wire size other than that stamped on the rolls, the roll(s) and guide tubes must be changed.

The drive rolls for 0.035 and 0.052 cored electrode and 1/16 through 7/64 electrode have a double set of teeth so they can be reversed for additional life. Drive rolls for 0.023 through 0.052 solid electrodes and aluminum sizes have no teeth, but use two grooves so they also can be reversed for additional life.

See the *Operation* Section for drive roll installation instructions.

See **Table C.2** in the *Accessories* section for drive roll and guide tube kits.

WIRE REEL MOUNTING - 50 AND 60 LB. COILS WITH 1" SPINDLE

To prolong the life of the reel shaft, periodically coat it with a thin layer of grease. No maintenance of the two-position adjustable brake is needed. If the brake shoe wears through to metal, replace the brake assembly.

WIRE REEL MOUNTING - READI-REELS AND 10 THROUGH 44 LB. SPOOLS AND 50 AND 60 LB. COILS WITH K1504-1 ADAPTER

No routine maintenance required. Do not lubricate the 2" spindle.

PERIODIC MAINTENANCE

CONTROL BOX

Every six months open and inspect the control section. The accumulated dirt should be gently blown off all of the electrical components. Be sure the air that is being used is dry. Check the contacts of the large plug-in relay.

A spatter resistant shield protects the digital meter. This shield must always be installed. If it breaks or becomes damaged, replace it by removing the two screws securing its frame, installing a new shield, and reattaching the frame.

WIRE DRIVE MOTOR AND GEAR BOX

Every year examine the gearbox. Paint the gear teeth with molydisulfide-filled grease (Lincoln specification E2322). Do not use a graphite grease.

Check the motor brushes. Replace if they are worn down to 1/4" or less. When ordering feed motor brushes, give all information from the motor nameplate.

GUN AND CABLE MAINTENANCE

For instructions on periodic maintenance for the welding gun and cables, refer to the manual for your specific model of welding gun.

PROPER SPEED SENSOR MODULE MOUNTING

The LN-9 GMA Speed Sensor Module is a three lead Hall-Effect switch device encased in an externally threaded housing. It is screwed into a mounting plate on the motor side of the wire drive gearbox. See Figure D.1.

Proper positioning of this module is critical to operation of the LN-9 GMA wire feed speed control. If the device is not screwed in far enough, the LN-9 GMA motor speed could be unstable or run at full speed with no control. If screwed in too far it will rub a moving part inside the gearbox.

The module is properly mounted to the gearbox as shipped from the factory. If the device is ever removed or replaced, proper mounting technique is as follows:

1. Be sure all power to the LN-9 GMA is shut off at the power source.
2. Check that the module mounting plate is screwed securely to the side of the gearbox and seated flush against the top surface after being tightened.
3. Gently screw the module into the mounting plate until it just touches and stops against the rotating part inside the gearbox.
4. Back the module out 1/2 turn, then snug the module locknut without rotating the module position.

FIGURE D.1 – SPEED SENSOR MODULE LOCATION

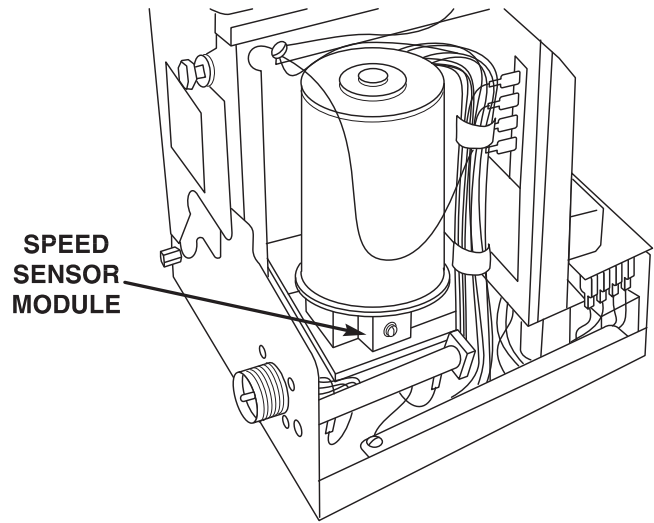

MAINTENANCE

GUN CABLE CONNECTOR REQUIREMENTS TO PERMIT PROPER CONNECTION TO LINCOLN LN-9 GMA AND LN-9F GMA WIRE FEEDER

The following Figures D.2 and D.3 should serve as a guide to determine if a particular gun or switch can be connected to the LN-9 GMA and LN-9F GMA.

FIGURE D.2 – LN-9 GMA CONNECTORS

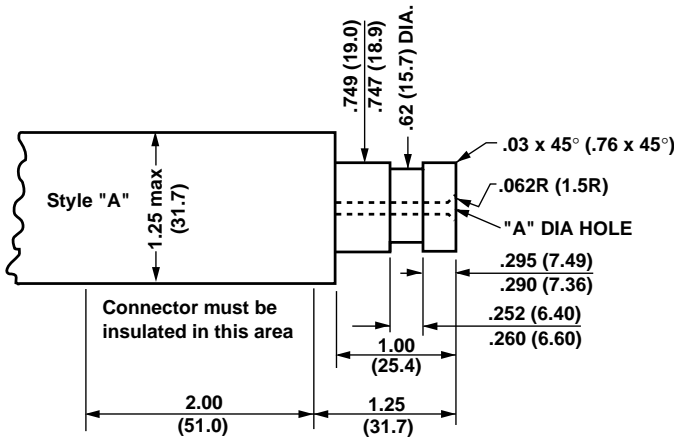

LN-9 CONNECTOR FOR 1/16-5/64" (1.6-2.0 MM) WIRE)

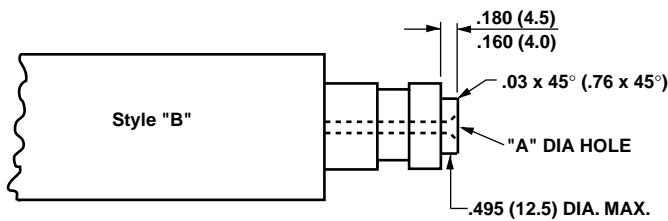

LN-9 CABLE CONNECTOR FOR .023-.052" (0.6-1.3 mm) WIRE (FOR ALL OTHER DIMENSIONS, SEE DIAGRAM ABOVE).

NOTE: Connector part with .7459/.747 (19.0/18.9) diameter should be made from brass if it is to be part of the welding current carrying circuit.

Wire Size in. (mm)	"A" Diameter Hole to be Concentric to .749/.747 (19.0/18.9) Diameter Within .008 (.20) F.I.M.
0.68-5/64 (1.7-2.0)	.125 [1/8" (3.2 mm) Drill]
1/16-0.062 (1.6)	.078 [5/64" (2.0 mm) Drill]
.045 & .052 (1.1 & 1.3)	.062 [1/16" (1.6 mm) Drill]
.023-.035 (0.6-0.9)	.055 [(1.4 mm) #54 Drill]

All dimensions in inches and (millimeters).

FIGURE D.2 – SWITCH REQUIREMENTS

1/2 Amp AC 24 Volts – Inductive
1/2 Amp DC 24 Volts – Inductive

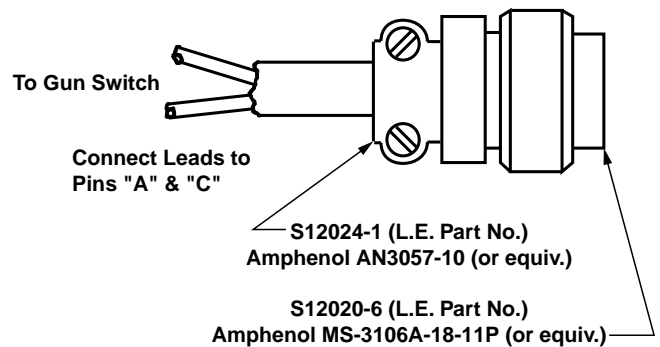

HOW TO USE TROUBLESHOOTING GUIDE

WARNING

This Troubleshooting Guide is designed to be used by the machine Owner/Operator. Unauthorized repairs performed on this equipment may result in danger to the technician and machine operator and will invalidate your factory warranty. For your safety, please observe all safety notes and precautions detailed in the Safety Section of this manual to avoid electrical shock or danger while troubleshooting this equipment.

This Troubleshooting Guide is provided to help you locate and repair possible machine misadjustments. Simply follow the three-step procedure listed below.

Step 1. LOCATE PROBLEM (SYMPTOM)

Look under the column labeled "PROBLEM (SYMPTOMS)". This column describes possible symptoms that your machine may exhibit. Find the listing that best describes the symptom that your machine is exhibiting. Problems are divided into "WIRE FEEDING PROBLEMS" or "WELDING PROBLEMS."

Step 2. PERFORM EXTERNAL RECOMMENDED TESTS

The second column labeled "POSSIBLE AREAS OF MISADJUSTMENT(S)" lists the obvious external possibilities that may contribute to the machine symptom. Perform these tests/checks in the order listed.

Step 3. CONSULT LOCAL AUTHORIZED FIELD SERVICE FACILITY

If you have exhausted all of the recommended tests in step 2, consult your local Authorized Field Service Facility.

CAUTION

If for any reason you do not understand the test procedures or are unable to perform the necessary tests/repairs safely, contact the Lincoln Electric Service Department for technical troubleshooting assistance before you proceed. **Call 1-800-833-WELD or 216-383-2531.**

TROUBLESHOOTING

TROUBLESHOOTING GUIDE

Observe Safety Guidelines detailed in the beginning of this manual.

PROBLEMS (SYMPTOMS)	POSSIBLE AREAS OF MISADJUSTMENT(S)	RECOMMENDED COURSE OF ACTION
WIRE FEEDING PROBLEMS		
<p>Drive rolls turn but wire will not feed, or wire feeding is rough or uneven.</p>	<ol style="list-style-type: none"> 1. Check that the gun cable is not kinked and/or twisted. Keep the cable as straight as possible. Inspect the cable and replace if necessary. 2. Check for wire jammed in the gun and cable. Remove wire from the gun and cable - feed in new wire. Note any obstruction. Replace the gun and cable if necessary. 3. Check for incorrect drive rolls and guide tubes, or incorrect drive roll assembly or pressure setting. Be sure the wire diameter being used is stamped on the drive rolls and guide tubes. Replace if necessary. Check for proper pressure setting and assembly. 4. Check to see if the gun cable is dirty. Clean the cable per manual instructions. 5. Check for worn drive roll or idle roll. Replace or reverse split drive roll type. 6. Check to see if the electrode is rusty and/or dirty. Replace the electrode if it is rusty. If conditions are extremely dirty or electrode is old (solid wire only) put a wiper on the wire before it enters the guide tube. Use a piece of cloth or felt saturated with "Pyroil B" held around the wire with a light clamp. 7. Check for a worn nozzle liner. Replace nozzle liner if necessary. 8. Check for partially flashed or melted contact tip. Replace the contact tip if necessary. 	<p>If all recommended possible areas of misadjustment have been checked and the problem persists, contact your local Lincoln Authorized Field Service Facility.</p>

⚠ CAUTION

If for any reason you do not understand the test procedures or are unable to perform the necessary tests/repairs safely, contact the Lincoln Electric Service Department for technical troubleshooting assistance before you proceed. **Call 1-800-833-WELD or 216-383-2531.**

LN-9 GMA and LN-9F GMA Wire Feeder



TROUBLESHOOTING GUIDE

Observe Safety Guidelines detailed in the beginning of this manual.

PROBLEMS (SYMPTOMS)	POSSIBLE AREAS OF MISADJUSTMENT(S)	RECOMMENDED COURSE OF ACTION
WIRE FEEDING PROBLEMS		
<p>Gun trigger will not feed wire. Digital meter is not lit.</p>	<ol style="list-style-type: none"> 1. Check to see if the circuit breaker is tripped. Reset the circuit breaker. See the topic "Circuit Breaker" in the Operation section. 2. Check to see if the power supply fuse is blown. Replace the fuse. See the topic "Power Supply Fuse" in the Operation section. 3. Check to see if there is 115 VAC supply from the power source. Check that power source is "on". If so, check the power source AC fuse. 4. The control cable may be faulty. Check or replace. 	<p>If all recommended possible areas of misadjustment have been checked and the problem persists, contact your local Lincoln Authorized Field Service Facility.</p>

⚠ CAUTION

If for any reason you do not understand the test procedures or are unable to perform the necessary tests/repairs safely, contact your **local authorized field service facility** before you proceed.

TROUBLESHOOTING GUIDE

Observe Safety Guidelines detailed in the beginning of this manual.

PROBLEMS (SYMPTOMS)	POSSIBLE AREAS OF MISADJUSTMENT(S)	RECOMMENDED COURSE OF ACTION
WIRE FEEDING PROBLEMS		
<p>Gun trigger will not feed wire. Meter is "on" and reads SET value of VOLTS or WIRE SPEED.</p>	<ol style="list-style-type: none"> 1. Check to see if the grounding lead protector (GLP) circuit has tripped. Clear any fault discovered between the electrode circuit and the wire feeder frame and then press the "GLP Reset" button. See the topic "Avoiding Grounding Lead Protector Shutdown" in the Operation section. 2. Check the gun trigger circuit. 	<p>If all recommended possible areas of misadjustment have been checked and the problem persists, contact your local Lincoln Authorized Field Service Facility.</p>

⚠ CAUTION

If for any reason you do not understand the test procedures or are unable to perform the necessary tests/repairs safely, contact your **local authorized field service facility** before you proceed.

TROUBLESHOOTING GUIDE

Observe Safety Guidelines detailed in the beginning of this manual.

PROBLEMS (SYMPTOMS)	POSSIBLE AREAS OF MISADJUSTMENT(S)	RECOMMENDED COURSE OF ACTION
WIRE FEEDING PROBLEMS		
<p>Gun trigger works and arc can be struck. Unit then shuts down while welding, or voltage output too low to establish arc (LN-9 ACTUAL VOLTS meter reading is low, zero or negative when trigger is closed).</p>	<ol style="list-style-type: none"> 1. Check to see if the wire feeder or power source "Electrode Polarity" switches are set properly. Set Polarity Switches in proper position. See the topic "Electrode Polarity Switch" in the <i>Operation</i> section. 2. Check to make sure lead #21 has continuity (zero ohms) to the work piece. 3. Check that the power source voltage control is set for REMOTE. R3S or DC-power source voltage control switch must be set to REMOTE. 4. Check that the LN-9 GMA control cable leads or weld cables are properly connected to the power source. Refer to the connection diagram for the Lincoln power source being used. 5. Check to see if the 1/8 A fuse on Voltage P.C. board is blown. If it is, determine cause of fuse blowing. 6. Determine whether the welding power source is able to supply SET voltage. If not, reset the output range controls of the power source so it can supply SET voltage. 	<p>If all recommended possible areas of misadjustment have been checked and the problem persists, contact your local Lincoln Authorized Field Service Facility.</p>

⚠ CAUTION

If for any reason you do not understand the test procedures or are unable to perform the necessary tests/repairs safely, contact your **local authorized field service facility** before you proceed.

LN-9 GMA and LN-9F GMA Wire Feeder



TROUBLESHOOTING GUIDE

Observe Safety Guidelines detailed in the beginning of this manual.

PROBLEMS (SYMPTOMS)	POSSIBLE AREAS OF MISADJUSTMENT(S)	RECOMMENDED COURSE OF ACTION
WELDING PROBLEMS		
Variable or "hunting" arc.	<ol style="list-style-type: none"> 1. Check for worn or incorrect sized contact tip. Replace tip if necessary. 2. Check for worn or undersized work cables. Repair or replace if necessary. 3. Check for loose electrode connections. Be sure the following connections are tight: Electrode cable to wire feeder and power source, work cable to power source and work, gun cable to wire feeder contact block, gun nozzle to body, and contact tip to nozzle. 4. Check whether the Voltage Control Response is properly set for the power source and the process. See the topic "<i>Voltage Control Response</i>" in the <i>Operation</i> section. 	If all recommended possible areas of misadjustment have been checked and the problem persists, contact your local Lincoln Authorized Field Service Facility.

⚠ CAUTION

If for any reason you do not understand the test procedures or are unable to perform the necessary tests/repairs safely, contact your **local authorized field service facility** before you proceed.

LN-9 GMA and LN-9F GMA Wire Feeder



TROUBLESHOOTING GUIDE

Observe Safety Guidelines detailed in the beginning of this manual.

PROBLEMS (SYMPTOMS)	POSSIBLE AREAS OF MISADJUSTMENT(S)	RECOMMENDED COURSE OF ACTION
WELDING PROBLEMS		
<p>Poor arc striking with sticking or "blast-offs", weld porosity, narrow and ropy-looking bead, or electrode stubbing into plate while welding.</p>	<ol style="list-style-type: none"> 1. Verify that the welding techniques or procedures being used are proper. See "Gas Metal Arc Welding Guide" (GS-100), "Innershield Production Welding Guide" (N675), "Outershield Procedure Guidelines" (GSP-70, GSP-71), "Procedure Guidelines for Pulsed Spray Welding" (GSP-PULSE) or "How To Make Submerged Arc Welders" (S604). 2. Check that the wire feed acceleration setting is proper for the process. See the topic "Starting Characteristics" in the Operation section for proper acceleration setting. 3. Check that the Voltage Control Response is properly set for the power source and process. See the topic "Voltage Control Response" in the Operation section and the appropriate power source connection diagram. 	<p>If all recommended possible areas of misadjustment have been checked and the problem persists, contact your local Lincoln Authorized Field Service Facility.</p>

⚠ CAUTION

If for any reason you do not understand the test procedures or are unable to perform the necessary tests/repairs safely, contact your **local authorized field service facility** before you proceed.

DIAGRAMS

LN-9 GMA DIMENSION PRINT

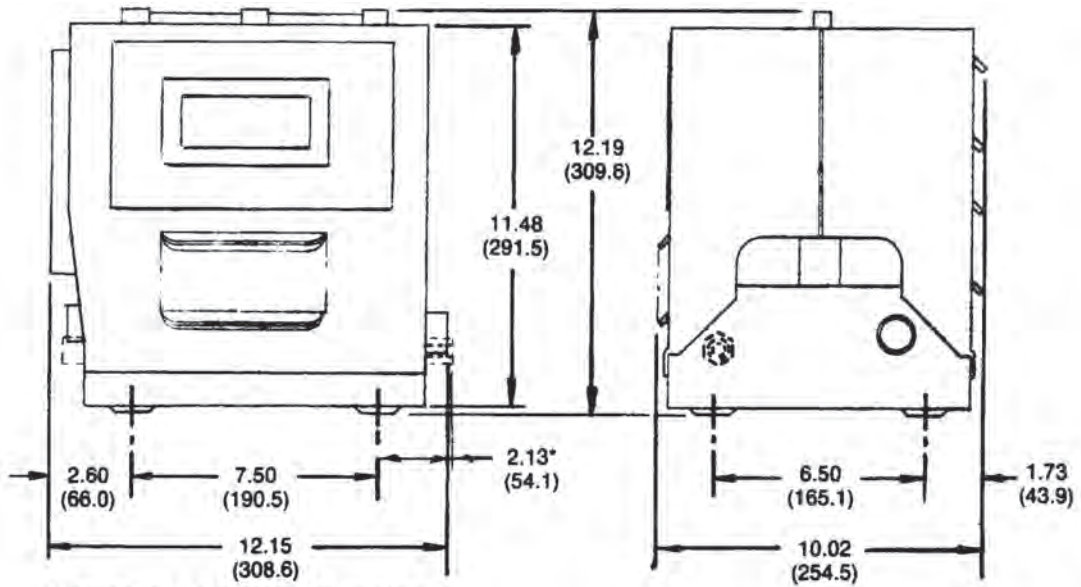

S16495
11-14-86B

Dimensions in inches and (millimeters).
* Only for LN-9 GMA models with gas hose fittings.

DIAGRAMS

LN-9F GMA DIMENSION PRINT (1 OF 2) WIRE DRIVE UNIT

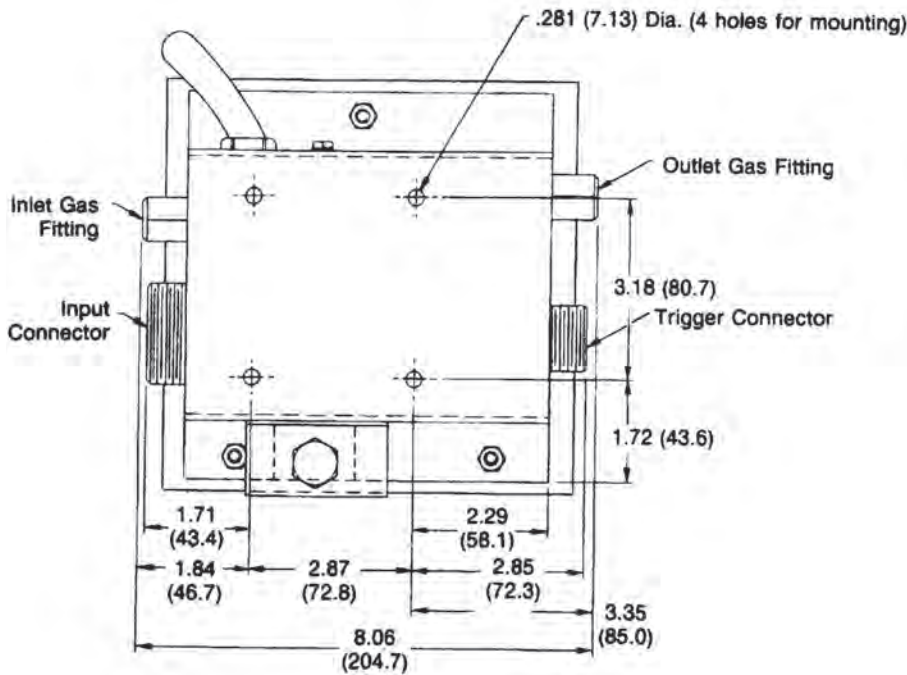
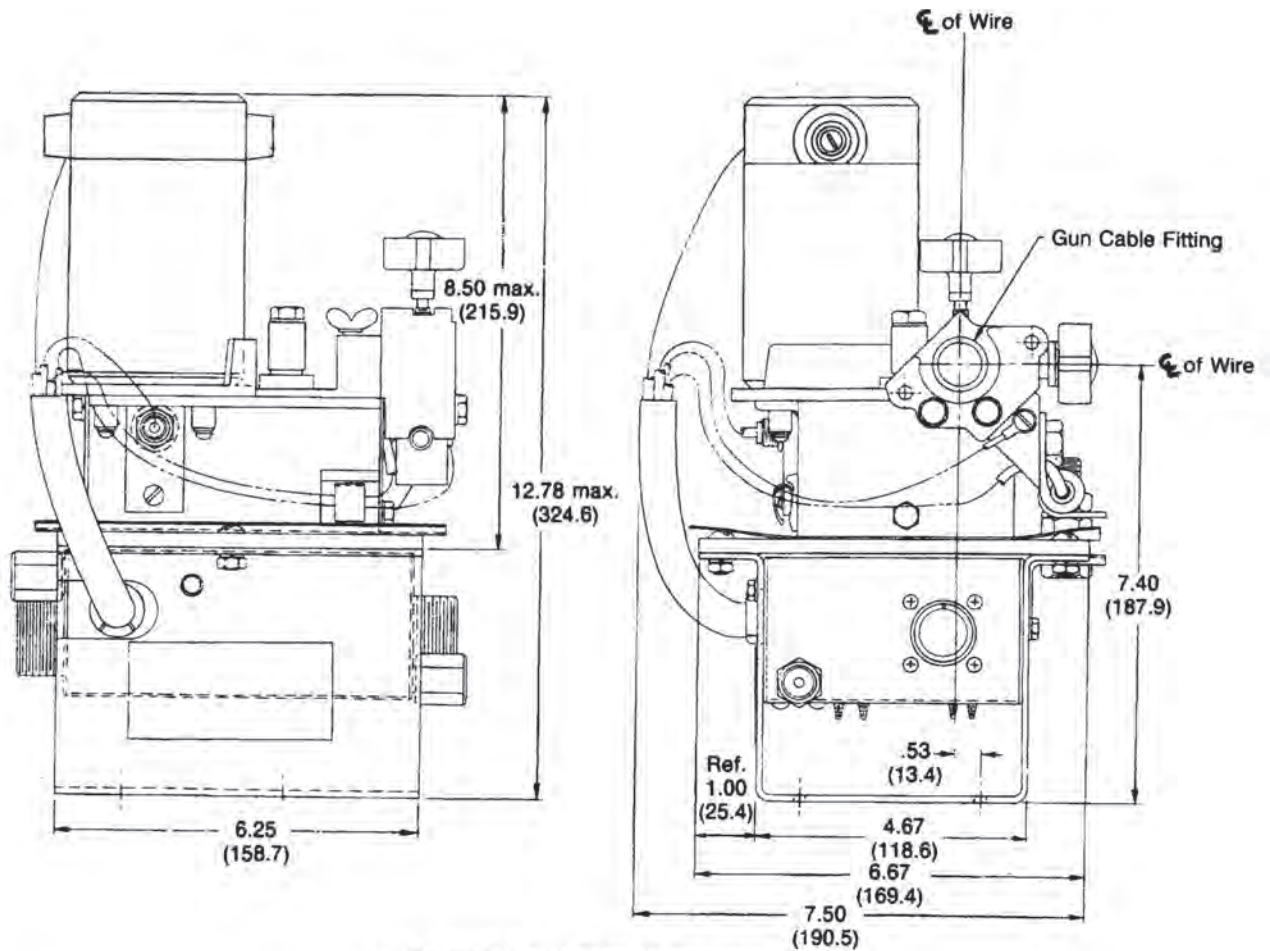

L7375
1-23-87

Dimensions in inches and (millimeters).

LN-9 GMA and LN-9F GMA Wire Feeder



DIAGRAMS

LN-9F DIMENSION PRINT (2 OF 2) CONTROL BOX

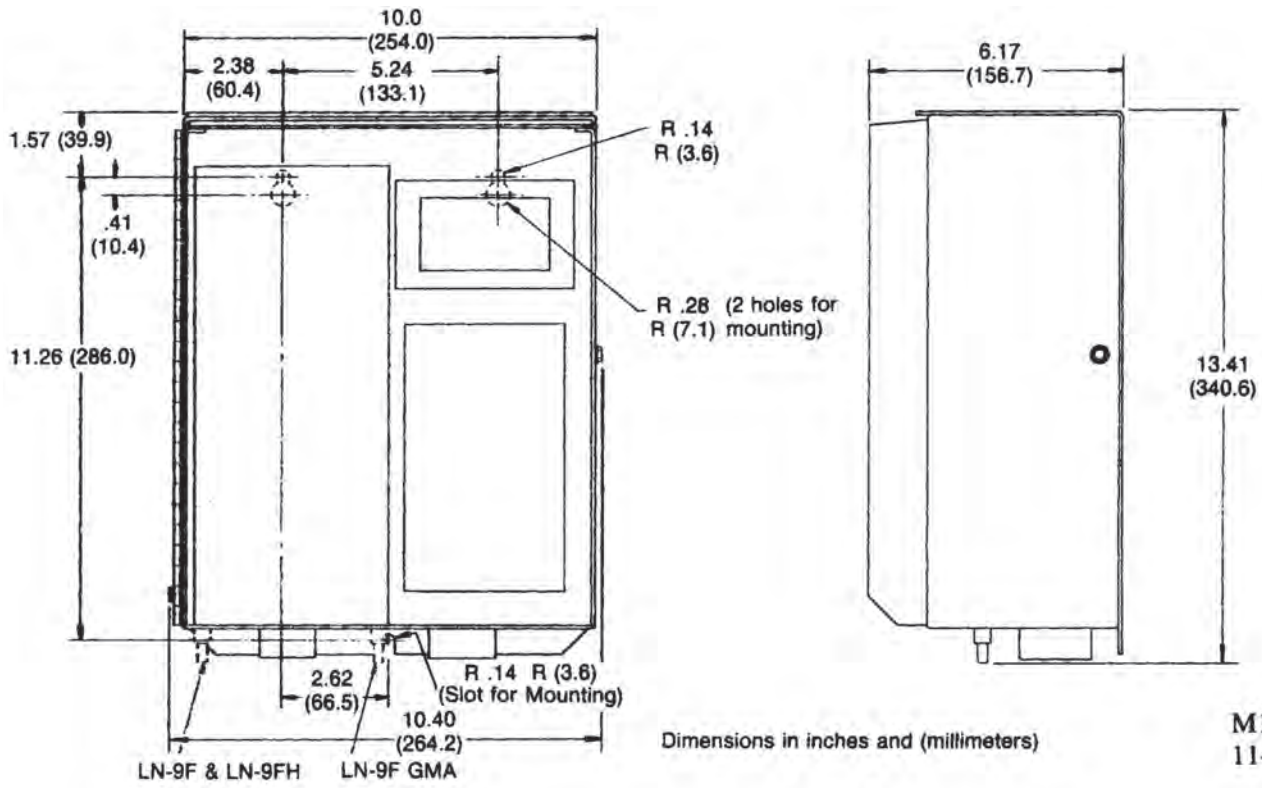

LN-9 GMA and LN-9F GMA Wire Feeder



NOTES

			
WARNING	<ul style="list-style-type: none"> ● Do not touch electrically live parts or electrode with skin or wet clothing. ● Insulate yourself from work and ground. 	<ul style="list-style-type: none"> ● Keep flammable materials away. 	<ul style="list-style-type: none"> ● Wear eye, ear and body protection.
Spanish AVISO DE PRECAUCION	<ul style="list-style-type: none"> ● No toque las partes o los electrodos bajo carga con la piel o ropa mojada. ● Aislese del trabajo y de la tierra. 	<ul style="list-style-type: none"> ● Mantenga el material combustible fuera del área de trabajo. 	<ul style="list-style-type: none"> ● Protéjase los ojos, los oídos y el cuerpo.
French ATTENTION	<ul style="list-style-type: none"> ● Ne laissez ni la peau ni des vêtements mouillés entrer en contact avec des pièces sous tension. ● Isolez-vous du travail et de la terre. 	<ul style="list-style-type: none"> ● Gardez à l'écart de tout matériel inflammable. 	<ul style="list-style-type: none"> ● Protégez vos yeux, vos oreilles et votre corps.
German WARNUNG	<ul style="list-style-type: none"> ● Berühren Sie keine stromführenden Teile oder Elektroden mit Ihrem Körper oder feuchter Kleidung! ● Isolieren Sie sich von den Elektroden und dem Erdboden! 	<ul style="list-style-type: none"> ● Entfernen Sie brennbares Material! 	<ul style="list-style-type: none"> ● Tragen Sie Augen-, Ohren- und Körperschutz!
Portuguese ATENÇÃO	<ul style="list-style-type: none"> ● Não toque partes elétricas e electrodos com a pele ou roupa molhada. ● Isole-se da peça e terra. 	<ul style="list-style-type: none"> ● Mantenha inflamáveis bem guardados. 	<ul style="list-style-type: none"> ● Use proteção para a vista, ouvido e corpo.
Japanese 注意事項	<ul style="list-style-type: none"> ● 通電中の電気部品、又は溶材にヒブやぬれた布で触れないこと。 ● 施工物やアースから身体が絶縁されている様にして下さい。 	<ul style="list-style-type: none"> ● 燃えやすいものの側での溶接作業は絶対にしてはなりません。 	<ul style="list-style-type: none"> ● 目、耳及び身体に保護具をして下さい。
Chinese 警告	<ul style="list-style-type: none"> ● 皮肤或湿衣物切勿接触带电部件及焊条。 ● 使你自已与地面和工件绝缘。 	<ul style="list-style-type: none"> ● 把一切易燃物品移离工作场所。 	<ul style="list-style-type: none"> ● 佩戴眼、耳及身体劳动保护用具。
Korean 위험	<ul style="list-style-type: none"> ● 전도체나 용접봉을 젖은 헝겍 또는 피부로 절대 접촉치 마십시오. ● 모재와 접지를 접촉치 마십시오. 	<ul style="list-style-type: none"> ● 인화성 물질을 접근 시키지 마시오. 	<ul style="list-style-type: none"> ● 눈, 귀와 몸에 보호장구를 착용하십시오.
Arabic تحذير	<ul style="list-style-type: none"> ● لا تلمس الاجزاء التي يسري فيها التيار الكهربائي أو الإلكترود بجلد الجسم أو بالمعلايس المبللة بالماء. ● وضع عازلا على جسمك خلال العمل. 	<ul style="list-style-type: none"> ● وضع المواد القابلة للاشتعال في مكان بعيد. 	<ul style="list-style-type: none"> ● وضع أدوات وملابس واقية على عينيك وأذنيك وجسمك.

READ AND UNDERSTAND THE MANUFACTURER'S INSTRUCTION FOR THIS EQUIPMENT AND THE CONSUMABLES TO BE USED AND FOLLOW YOUR EMPLOYER'S SAFETY PRACTICES.

SE RECOMIENDA LEER Y ENTENDER LAS INSTRUCCIONES DEL FABRICANTE PARA EL USO DE ESTE EQUIPO Y LOS CONSUMIBLES QUE VA A UTILIZAR, SIGA LAS MEDIDAS DE SEGURIDAD DE SU SUPERVISOR.

LISEZ ET COMPRENEZ LES INSTRUCTIONS DU FABRICANT EN CE QUI REGARDE CET EQUIPMENT ET LES PRODUITS A ETRE EMPLOYES ET SUIVEZ LES PROCEDURES DE SECURITE DE VOTRE EMPLOYEUR.

LESEN SIE UND BEFOLGEN SIE DIE BETRIEBSANLEITUNG DER ANLAGE UND DEN ELEKTRODENEINSATZ DES HERSTELLERS. DIE UNFALLVERHÜTUNGSVORSCHRIFTEN DES ARBEITGEBERS SIND EBENFALLS ZU BEACHTEN.

			
<ul style="list-style-type: none"> ● Keep your head out of fumes. ● Use ventilation or exhaust to remove fumes from breathing zone. 	<ul style="list-style-type: none"> ● Turn power off before servicing. 	<ul style="list-style-type: none"> ● Do not operate with panel open or guards off. 	WARNING
<ul style="list-style-type: none"> ● Los humos fuera de la zona de respiración. ● Mantenga la cabeza fuera de los humos. Utilice ventilación o aspiración para gases. 	<ul style="list-style-type: none"> ● Desconectar el cable de alimentación de poder de la máquina antes de iniciar cualquier servicio. 	<ul style="list-style-type: none"> ● No operar con panel abierto o guardas quitadas. 	Spanish AVISO DE PRECAUCION
<ul style="list-style-type: none"> ● Gardez la tête à l'écart des fumées. ● Utilisez un ventilateur ou un aspirateur pour ôter les fumées des zones de travail. 	<ul style="list-style-type: none"> ● Débranchez le courant avant l'entretien. 	<ul style="list-style-type: none"> ● N'opérez pas avec les panneaux ouverts ou avec les dispositifs de protection enlevés. 	French ATTENTION
<ul style="list-style-type: none"> ● Vermeiden Sie das Einatmen von Schweißrauch! ● Sorgen Sie für gute Be- und Entlüftung des Arbeitsplatzes! 	<ul style="list-style-type: none"> ● Strom vor Wartungsarbeiten abschalten! (Netzstrom völlig öffnen; Maschine anhalten!) 	<ul style="list-style-type: none"> ● Anlage nie ohne Schutzgehäuse oder Innenschutzverkleidung in Betrieb setzen! 	German WARNUNG
<ul style="list-style-type: none"> ● Mantenha seu rosto da fumaça. ● Use ventilação e exaustão para remover fumo da zona respiratória. 	<ul style="list-style-type: none"> ● Não opere com as tampas removidas. ● Desligue a corrente antes de fazer serviço. ● Não toque as partes elétricas nuas. 	<ul style="list-style-type: none"> ● Mantenha-se afastado das partes moventes. ● Não opere com os painéis abertos ou guardas removidas. 	Portuguese ATENÇÃO
<ul style="list-style-type: none"> ● ヒュームから顔を離すようにして下さい。 ● 換気や排煙に十分留意して下さい。 	<ul style="list-style-type: none"> ● メンテナンス・サービスに取りかかる際には、まず電源スイッチを必ず切して下さい。 	<ul style="list-style-type: none"> ● パネルやカバーを取り外したままで機械操作をしないで下さい。 	Japanese 注意事項
<ul style="list-style-type: none"> ● 頭部遠離煙霧。 ● 在呼吸區使用通風或排風器除煙。 	<ul style="list-style-type: none"> ● 維修前切斷電源。 	<ul style="list-style-type: none"> ● 儀表板打開或沒有安全罩時不準作業。 	Chinese 警告
<ul style="list-style-type: none"> ● 얼굴로부터 용접가스를 멀리하십시오. ● 호흡지역으로부터 용접가스를 제거하기 위해 가스제거기나 통풍기를 사용하십시오. 	<ul style="list-style-type: none"> ● 보수전에 전원을 차단하십시오. 	<ul style="list-style-type: none"> ● 관널이 열린 상태로 작동치 마십시오. 	Korean 위험
<ul style="list-style-type: none"> ● ابعء رأسك بعيداً عن الدخان. ● استعمل التهوية أو جهاز ضغط الدخان للخارج لكي تبعد الدخان عن المنطقة التي تتنفس فيها. 	<ul style="list-style-type: none"> ● اقطع التيار الكهربائي قبل القيام بأية صيانة. 	<ul style="list-style-type: none"> ● لا تشغيل هذا الجهاز اذا كانت الاغطية الحديدية الواقية ليست عليه. 	Arabic تحذير

LEIA E COMPREENDA AS INSTRUÇÕES DO FABRICANTE PARA ESTE EQUIPAMENTO E AS PARTES DE USO, E SIGA AS PRÁTICAS DE SEGURANÇA DO EMPREGADOR.

使う機械や溶材のメーカーの指示書をよく読み、まず理解して下さい。そして貴社の安全規定に従って下さい。

請詳細閱讀並理解製造廠提供的說明以及應該使用的銀焊材料，並請遵守貴方的有關勞動保護規定。

이 제품에 동봉된 작업지침서를 숙지하시고 귀사의 작업자 안전수칙을 준수하시기 바랍니다.

اقرأ بتعمق وافهم تعليمات المصنع المنتج لهذه المعدات والمواد قبل استعمالها واتبع تعليمات الوقاية لصاحب العمل.

LN-9 GMA WIRE FEEDER





• World's Leader in Welding and Cutting Products •

• Sales and Service through Subsidiaries and Distributors Worldwide •

Cleveland, Ohio 44117-1199 U.S.A. TEL: 216.481.8100 FAX: 216.486.1751 WEB SITE: www.lincolnelectric.com