

The BotX[™] XHR Advantage

- Innovative on-demand model - align operations with current business needs
- Easy to use robotic welding system - weld complex parts in minutes
- Real-time monitoring, production and quality data, automatic system enhancements
- 24/7 support through the Beacon app
- RIA TR 15.606-2016 compliant

System Components

- 4' x 4', 4' x 8' fixed position table or 4' x 2'- 6" mobile cart
- Universal Robots UR10e
- Welding torch and mounting assembly
- Torch lead and cable support arm
- XMT 350, EX360 MAP or 450 MPa welder
- Miller S74 MPa Plus cobotic wire feeder
- Two-button "smart puck"
- Two, color touch buttons for user input
- Real-time dashboards and charts
- 66 piece starter tooling kit
- 24/7 support
- Beacon software with ongoing virtual support
- Onsite install and training included with rental and lease options



Universal Robots UR10e Welding Arm

Power	Noise	IP Classification	Pose Repeatability	Reach
Approx. 350 W using a typical program	Less than 65 dB(A)	IP54	+/- 0.05 mm, with payload, per ISO 9283	51" [1295.4 mm]

Power Sources

Model	Input Power	Welding Amperage/Voltage Range	Rated Output
XMT 350	Auto-Line 208-575/1/3/50/60	5 - 425 V in CC mode 10 - 38 V in CV mode	350 A at 34 VDC, 60% duty cycle, 3-Phase 300 A at 32 VDC, 60% duty cycle, 1-Phase
EX360 MAP	Auto-Line 208-575/1/3/50/60	5 - 425 A in CC mode 10 - 38 V in CV mode	350 A at 34 V, 60% duty cycle, 3-Phase 300 A at 32 V, 60% duty cycle, 1-Phase
450 MPa**	230/460/575/3/60	15 - 600 A in CC mode 10 - 38 V in CV mode	450 A at 38 VDC, 100% duty cycle

**450 MPa power source is not available with the 4' x 2'- 6" mobile cart
Other welding packages are available to suit your specific requirements

4' x 2'- 6" Mobile Cart

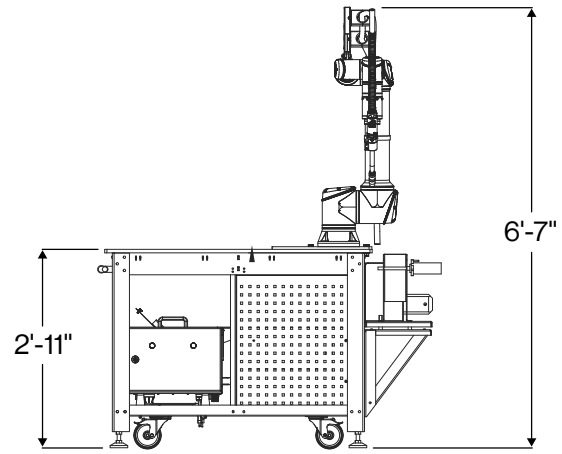
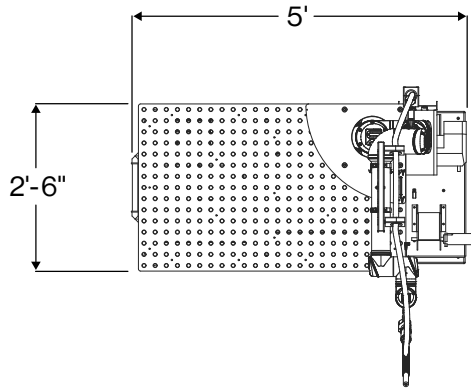

4' x 4' Fixed Position Table

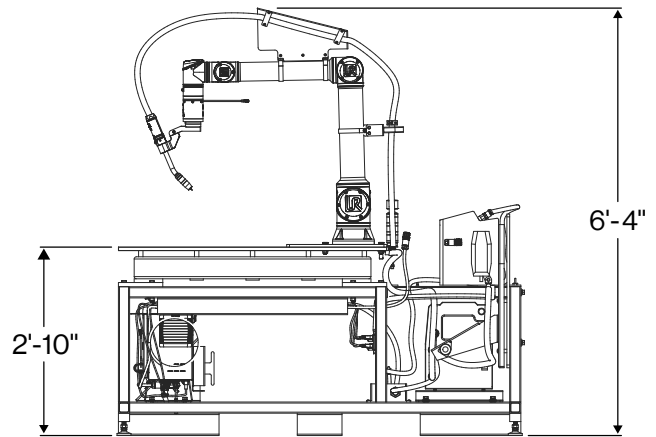
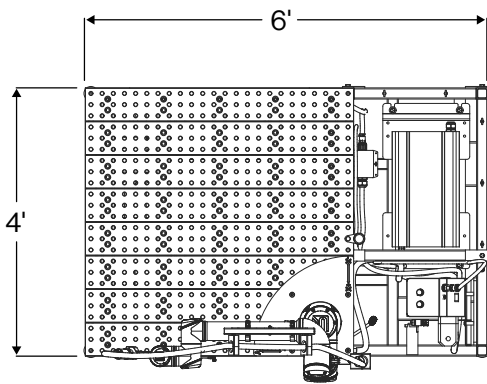

4' x 8' Fixed Position Table

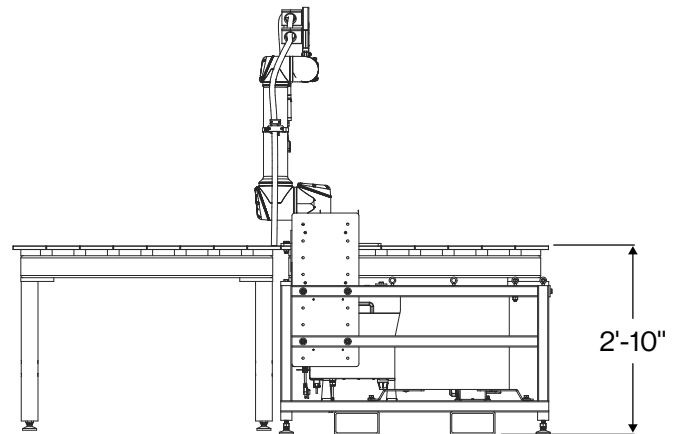
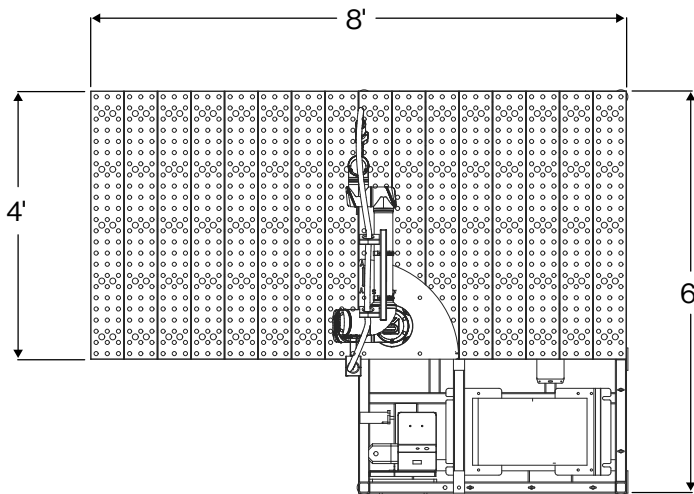

For more information call **1-866-620-7737** or visit **BotXWelder.com**

Rental | Lease | Purchase

Specifications are subject to change without notice

Red-D-Arc

©2019 Airgas, Inc. 9600067 - OCT 23